

5 Tons

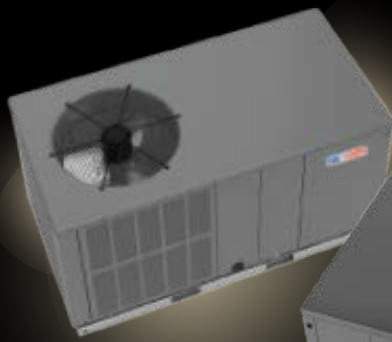

2-4 Tons



APG16M

High-Efficiency Packaged Gas / Electric
2 to 5 Tons

Cooling Capacity: 22,800 – 58,500 BTU/h
Heating Capacity: 60,000 – 140,000 BTU/h

Nomenclature	2
Product Specifications	3
Expanded Cooling Data	4
Airflow Data	16
Dimensions	18
Wiring Diagrams	21
Accessories	24

Standard Features

- Heavy-duty stainless-steel heat exchanger
- High-efficiency two-stage scroll compressor with factory-in stalled sound blanket
- Variable-speed ECM indoor blower motor
- Copper tube / aluminum fin condenser coils
- All-aluminum evaporator coil on 2- to 4-ton units
- Aluminum-copper evaporator coil on 5-ton units
- Two-stage gas valve; natural gas with easy conversion to propane with accessory kit
- Power-assisted combustion
- AHRI Certified; ETL Listed
- All blower operation and all safety circuits complete with self-diagnostics
- Direct-spark ignition system, including a micro-processor-based control for the entire ignition sequence
- Loss-of-charge protection and high-pressure switch
- California Low NOx approved For installation in California's South Coast Air Quality Management District (SCAQMD) only: This furnace does not meet the SCAQMD Rule 1111 14 ng/J NOx emission limit, and thus is subject to a mitigation fee of up to \$450. This furnace is not eligible for the SCAQMD Clean Air Furnace Rebate Program:
www.CleanAirFurnaceRebate.com.

Cabinet Features



- Fully insulated heavy-gauge, zinc-coated steel cabinet with UV-resistant powder-paint finish
- Aluminum foil-facing internal insulation reinforced with fiberglass scrim
- Compressor grommets for vibration isolation
- Convenient access panels
- One roof curb fits 2-4 ton units
- Bottom 2" high base rails for easier handling
- 2-4 ton models fit a standard-size pick-up truck
- When properly anchored, meets 2010 Florida Building Code unit integrity requirements for hurricane-type winds (Anchor bracket kits available.)



* Complete warranty details available on www.nexgenairandheat.com. To receive the Lifetime Unit Replacement Warranty (good for as long as you own your home) and 10-Year Parts Lifetime Warranty, in order to qualify for lifetime replacement warranty you need to be part of the X Protection Family. Membership must be current and up-to-date.

* Complete warranty details available on www.nexgenairandheat.com. To receive the Lifetime Unit Replacement Lifetime Warranty (good for as long as you own your home) and 10-Year Parts Lifetime Warranty, in order to qualify for lifetime replacement warranty you need to be part of the X Protection Family. Membership must be current and up-to-date.

	A	P	G	16	36	080	M	4	1	**	
	1	2	3	4,5	6,7	8,9,10	11	12	13	14,15	
Brand	A - Amana® brand A - Nexgen Brand									Engineering Major/ Minor Revisions (not used for inventory control)	
Product Category	P Packaged Unit									Electrical 1 208-230/1/60	
Unit Type	G Gas/Electric D Dual-Fuel									Refrigerant 4 R-410A	
Efficiency	14 14 SEER 16 16 SEER									Airflow M Multi-Position	
Nominal Capacity	24 2 Tons 36 3 Tons 42 3½ Tons									Heat Input 60 60 MBTU/h 100 100 MBTU/h 80 80 MBTU/h 120 120 MBTU/h 140 138 MBTU/h	

	APG1624 060M41AA	APG1630 080M41AA	APG1636 080M41AA	APG1642 100M41AA	APG1648 100M41AA	APG1660 140M41A*
COOLING CAPACITY (BTU/H)						
Total	22,800	28,600	34,200	40,000	45,500	58,500
Sensible	18,200	21,800	27,400	29,600	32,800	43,500
SEER / EER	16.0 / 12.0	15.5 / 12.0	16.0 / 12.0	16.0 / 12.0	16.0 / 12.0	16.0 / 12.0
Decibels	76	76	76	78	78	78
AHRI #s	8082388	8082389	8082390	8082391	8082392	9134478
HEATING CAPACITY (BTU/H)						
High-Fire Input / Output	60,000 / 47,000	80,000 / 62,000	80,000 / 62,000	100,000 / 78,000	100,000 / 78,000	138,000 / 112,000
Low-Fire Input / Output	45,000 / 35,000	60,000 / 47,000	60,000 / 47,000	75,000 / 58,000	75,000 / 58,000	103,000 / 84,000
AFUE	81	81	81	81	81	81
Temperature Rise Range	35 - 65	35 - 65	35 - 65	35 - 65	35 - 65	55-105
No. of Burners	3	4	4	5	5	6
Orifice Size (Gas / LP)	45 / 1.25mm	45 / 1.25mm	45 / 1.25mm	45 / 1.25mm	45 / 1.25mm	53 / 1.51MM
EVAPORATOR MOTOR						
Type	ECM	ECM	ECM	ECM	ECM	ECM
Wheel (DxW)	10" x 8"	10" x 9"	11" x 10"	11" x 10"	11" x 10"	11" x 10"
Indoor Nominal CFM	800	950	1,200	1,250	1,300	1,850
Motor Speed Tap (Cooling)	Variable	Variable	Variable	Variable	Variable	Variable
RPM / Amps (Cooling)	1050 / 4.3	1050 / 4.3	1050 / 6.8	1050 / 6.8	1050 / 6.8	1050 / 7
Horsepower / RPM	1/2	1/2	3/4	3/4	3/4	1
EVAPORATOR COIL						
Face Area (ft ²)	4.3	4.3	5.7	5.7	5.7	8.9
Rows Deep / Fin per Inch	3 / 14	3 / 14	4 / 14	4 / 14	4 / 14	4 / 16
Expansion Device	TXV	TXV	TXV	TXV	TXV	TXV
Filter Size (ft ²)	3.5	4.3	4.3	5.6	5.6	8.9
Drain Size (NPT)	¾"	¾"	¾"	¾"	¾"	¾"
Refrigerant Charge -- R-410A (oz.)	70	70	158	143	100	154
CONDENSER FAN / COIL						
Horsepower - RPM	1/6 - 815	1/4 - 830	1/4 - 830	1/4 - 1,075	1/4 - 1,075	1/3 - 1,095
Fan Diameter / # of Fan Blades	22" / 3	22" / 3	22" / 3	22" / 3	22" / 3	22" / 4
Outdoor Nominal CFM	2,200	2,200	2,600	3,200	3,100	4,200
Face Area (ft ²)	12.3	8.7	14.9	14.9	14.4	19
Row Deep / Fins per Inch	1 / 24	2 / 27	2 / 16	2 / 16	2 / 27	2 / 27
COMPRESSOR						
Quantity / Type / Stage	1 / Scroll / 2	1 / Scroll / 2	1 / Scroll / 2	1 / Scroll / 2	1 / Scroll / 2	1 / Scroll / 2
Compressor RLA / LRA	11.7 / 58.3	13.1 / 73.0	15.3 / 83.0	17.9 / 96.0	21.2 / 104.0	27 / 153
ELECTRICAL DATA						
Voltage/ Phase (60 Hz)	208/230-1	208/230-1	208/230-1	208/230-1	208/230-1	208/230-1
Indoor Blower FLA	4.3	4.3	6.8	6.8	6.8	7
Outdoor Fan FLA / LRA	1.1 / 1.7	1.5 / 3.0	1.5 / 3.0	1.4 / 2.9	1.4 / 2.9	2 / 4.4
Total Unit Amps	17.1	18.9	23.6	26.1	29.4	36
Min. Circuit Ampacity ¹	20.0	22.2	27.4	30.6	34.7	43.0
Max. Overcurrent Protection ²	30 amps	35 amps	40 amps	45 amps	50 amps	60 amps
Entrance Size Power Supply	1½"	1½"	1½"	1½"	1½"	1½"
Entrance Size Control Voltage	¾"	¾"	¾"	¾"	¾"	1/2"
OPERATING / SHIP WEIGHTS (LBS)						
	370 / 380	397 / 407	470 / 480	495 / 505	490 / 500	630 / 655
ENERGY STAR® CERTIFIED						
	NO	NO				NO

¹ Wire size should be determined in accordance with National Electrical Codes. Extensive wire runs will require larger wire sizes.

² Must use time-delay fuses or HACR-type circuit breakers of the same size as noted.

Note: Always check the S&R plate for electrical data on the unit being installed.

IDB		OUTDOOR AMBIENT TEMPERATURE																							
		65				75				85				95				105				115			
		59	63	67	71	59	63	67	71	59	63	67	71	59	63	67	71	59	63	67	71	59	63	67	71
70	AIRFLOW	23.3	24.1	26.4	-	22.2	23.0	25.2	-	21.6	22.4	24.6	-	20.5	21.3	23.3	-	19.0	19.7	21.6	-	18.5	19.2	21.0	-
	MBh	0.80	0.67	0.46	-	0.85	0.71	0.49	-	0.88	0.73	0.51	-	0.91	0.76	0.53	-	0.92	0.77	0.53	-	0.88	0.73	0.51	-
	S/T	19	16	12	-	19	16	13	-	19	17	13	-	19	16	12	-	18	15	12	-	18	16	12	-
	Δ T	1.56	1.59	1.64	-	1.68	1.72	1.78	-	1.89	1.93	2.00	-	1.97	2.02	2.09	-	2.04	2.09	2.16	-	2.03	2.07	2.14	-
	kW	6.9	7.0	7.2	-	7.4	7.5	7.7	-	8.4	8.6	8.9	-	8.9	9.1	9.4	-	9.4	9.6	9.9	-	9.3	9.5	9.8	-
	Amps	237	255	269	-	266	286	302	-	344	371	391	-	388	417	440	-	428	461	487	-	428	461	487	-
	HI PR	112	119	130	-	118	126	137	-	123	131	143	-	135	144	157	-	140	149	162	-	140	149	162	-
	LO PR	22.6	23.4	25.6	-	22.0	22.9	25.0	-	21.5	22.3	24.4	-	19.9	20.7	22.7	-	18.5	19.2	21.0	-	18.5	19.2	21.0	-
	MBh	0.76	0.64	0.44	-	0.79	0.66	0.46	-	0.81	0.68	0.47	-	0.87	0.73	0.50	-	0.88	0.73	0.51	-	0.88	0.73	0.51	-
	S/T	20	17	13	-	20	17	13	-	20	17	13	-	20	17	13	-	20	17	13	-	20	17	13	-
Δ T	1.54	1.58	1.63	-	1.67	1.71	1.76	-	1.78	1.82	1.88	-	1.95	2.00	2.07	-	2.03	2.07	2.14	-	2.03	2.07	2.14	-	
kW	6.8	7.0	7.2	-	7.3	7.5	7.7	-	7.9	8.0	8.3	-	8.8	9.0	9.3	-	9.3	9.5	9.8	-	9.3	9.5	9.8	-	
Amps	235	253	267	-	263	283	299	-	299	322	340	-	384	413	436	-	424	456	482	-	424	456	482	-	
HI PR	111	118	129	-	117	124	136	-	122	129	141	-	134	142	155	-	138	147	161	-	138	147	161	-	
LO PR	20.8	21.6	23.7	-	20.4	21.1	23.1	-	19.9	20.6	22.6	-	18.4	19.1	20.9	-	17.1	17.7	19.4	-	17.1	17.7	19.4	-	
MBh	0.74	0.62	0.43	-	0.76	0.64	0.44	-	0.78	0.65	0.45	-	0.84	0.70	0.49	-	0.85	0.71	0.49	-	0.85	0.71	0.49	-	
S/T	20	17	13	-	20	17	13	-	20	17	13	-	20	17	13	-	20	17	13	-	20	17	13	-	
Δ T	1.51	1.54	1.59	-	1.63	1.66	1.72	-	1.73	1.77	1.83	-	1.90	1.95	2.01	-	1.97	2.02	2.09	-	1.97	2.02	2.09	-	
kW	6.6	6.8	7.0	-	7.1	7.3	7.5	-	7.7	7.8	8.1	-	8.6	8.8	9.1	-	9.1	9.3	9.6	-	9.1	9.3	9.6	-	
Amps	228	245	259	-	255	275	290	-	290	313	330	-	372	401	423	-	411	443	467	-	411	443	467	-	
HI PR	107	114	125	-	113	121	132	-	118	125	137	-	130	138	151	-	134	143	156	-	134	143	156	-	
LO PR																									

IDB		OUTDOOR AMBIENT TEMPERATURE																							
		65				75				85				95				105				115			
		59	63	67	71	59	63	67	71	59	63	67	71	59	63	67	71	59	63	67	71	59	63	67	71
75	AIRFLOW	23.6	24.3	26.4	28.3	23.1	23.8	25.7	27.6	22.5	23.2	25.1	27.0	22.0	22.6	24.5	26.3	20.9	21.5	23.3	25.0	19.4	19.9	21.6	23.2
	MBh	0.91	0.81	0.62	0.40	0.94	0.84	0.64	0.41	0.97	0.87	0.65	0.42	1.00	0.89	0.68	0.43	1.00	0.93	0.70	0.45	1.00	0.93	0.71	0.46
	S/T	22	20	16	11	22	20	17	11	22	20	17	11	22	20	17	12	21	20	17	11	20	19	15	11
	Δ T	1.57	1.61	1.66	1.71	1.70	1.73	1.79	1.85	1.81	1.85	1.91	1.98	1.91	1.95	2.02	2.09	1.99	2.03	2.10	2.18	2.06	2.11	2.18	2.26
	kW	6.9	7.1	7.3	7.5	7.4	7.6	7.8	8.1	8.0	8.2	8.4	8.7	8.5	8.7	8.9	9.2	9.0	9.2	9.5	9.8	9.5	9.7	10.0	10.3
	Amps	239	258	272	284	269	289	305	318	306	329	347	362	348	375	395	412	392	421	445	464	433	466	492	513
	HI PR	113	120	131	140	119	127	139	148	124	132	144	153	130	139	151	161	137	145	159	169	141	150	164	175
	LO PR	23.0	23.6	25.6	27.5	22.4	23.1	25.0	26.8	21.9	22.5	24.4	26.2	21.4	22.0	23.8	25.5	20.3	20.9	22.6	24.3	18.8	19.3	20.9	22.5
	MBh	0.87	0.78	0.59	0.38	0.90	0.80	0.61	0.39	0.92	0.83	0.62	0.40	0.95	0.85	0.64	0.41	0.99	0.88	0.67	0.43	1.00	0.89	0.67	0.43
	S/T	23	21	17	12	23	21	17	12	23	21	17	12	23	21	17	12	23	21	17	12	21	20	16	11
Δ T	1.56	1.59	1.64	1.70	1.68	1.72	1.78	1.84	1.79	1.83	1.89	1.96	1.89	1.93	2.00	2.07	1.97	2.02	2.09	2.16	2.04	2.09	2.16	2.24	
kW	6.9	7.0	7.2	7.5	7.4	7.5	7.7	8.0	7.9	8.1	8.3	8.6	8.4	8.6	8.9	9.2	8.9	9.1	9.4	9.7	9.4	9.6	9.9	10.2	
Amps	237	255	269	281	266	286	302	315	303	326	344	359	345	371	392	408	388	417	440	459	428	461	487	508	
HI PR	112	119	130	138	118	126	137	146	123	131	143	152	129	137	150	160	135	144	157	167	140	149	162	173	
LO PR	21.2	21.8	23.6	25.3	20.7	21.3	23.1	24.8	20.2	20.8	22.5	24.2	19.7	20.3	22.0	23.6	18.7	19.3	20.9	22.4	17.3	17.9	19.3	20.7	
MBh	0.84	0.75	0.57	0.36	0.87	0.78	0.59	0.38	0.89	0.80	0.60	0.39	0.92	0.82	0.62	0.40	0.95	0.85	0.65	0.42	0.96	0.86	0.65	0.42	
S/T	23	21	17	12	23	21	18	12	23	21	18	12	23	22	18	12	23	21	17	12	22	20	16	11	
Δ T	1.52	1.55	1.60	1.66	1.64	1.68	1.73	1.79	1.75	1.79	1.85	1.91	1.84	1.88	1.95	2.01	1.92	1.96	2.03	2.10	1.99	2.04	2.11	2.18	
kW	6.7	6.8	7.0	7.3	7.2	7.3	7.5	7.8	7.7	7.9	8.1	8.4	8.2	8.4	8.6	8.9	8.7	8.9	9.1	9.5	9.1	9.3	9.6	10.0	
Amps	230	247	261	273	258	278	293	306	293	316	333	348	334	360	380	396	376	405	427	446	415	447	472	492	
HI PR	108	115	126	134	115	122	133	142	119	127	138	147	125	133	145	155	131	140	152	162	136	144	158	168	
LO PR																									

IDB: Entering Indoor Dry Bulb Temperature
 High and low pressures are measured at the liquid and suction service valves.
 Shaded area reflects ACCA (TVA) conditions
 kW = Total system power
 Amps = outdoor unit amps (comp.+fan)

IDB		OUTDOOR AMBIENT TEMPERATURE															ENTERING INDOOR WET BULB TEMPERATURE																
		65					75					85					95					105					115						
		59	63	67	71	75	59	63	67	71	75	59	63	67	71	75	59	63	67	71	75	59	63	67	71	75	59	63	67	71	75		
80	MBh	24.1	24.6	26.3	28.1	23.5	24.0	25.7	27.4	22.9	23.4	25.1	26.8	22.4	22.9	24.4	26.1	21.3	21.7	23.2	24.8	20.6	21.1	22.5	24.1	19.1	19.5	20.9	22.3	20.6	21.1	22.5	24.1
	S/T	1.00	0.94	0.76	0.57	1.00	0.97	0.79	0.59	1.00	1.00	0.81	0.61	1.00	1.00	0.84	0.62	1.00	1.00	0.87	0.65	1.00	1.00	0.83	0.62	1.00	1.00	0.83	0.62	1.00	1.00	0.87	0.65
	Δ T	24	23	20	16	24	24	20	16	23	24	20	16	23	23	21	16	21	22	20	16	21	22	20	16	20	20	19	15	20	20	19	15
	kW	1.58	1.62	1.67	1.73	1.71	1.75	1.81	1.87	1.82	1.86	1.93	1.99	1.92	1.97	2.03	2.10	2.01	2.05	2.12	2.20	2.01	2.05	2.12	2.20	2.08	2.13	2.20	2.28	2.08	2.13	2.20	2.28
	Amps	7.0	7.1	7.3	7.6	7.5	7.6	7.9	8.1	8.1	8.2	8.5	8.8	8.6	8.7	9.0	9.3	9.1	9.3	9.5	9.9	9.5	9.6	9.9	10.4	9.5	9.8	10.1	10.4	9.5	9.8	10.1	10.4
	HI PR	242	260	275	287	271	292	308	322	309	332	351	366	352	378	399	417	395	426	449	469	437	470	497	518	437	470	497	518	437	470	497	518
	LO PR	114	121	133	141	121	128	140	149	125	133	146	155	132	140	153	163	138	147	160	171	143	152	166	176	143	152	166	176	143	152	166	176
	MBh	23.4	23.9	25.5	27.3	22.8	23.3	24.9	26.6	22.3	22.8	24.3	26.0	21.7	22.2	23.7	25.4	20.6	21.1	22.5	24.1	20.6	21.1	22.5	24.1	19.1	19.5	20.9	22.3	20.6	21.1	22.5	24.1
	S/T	0.95	0.89	0.73	0.54	0.99	0.93	0.75	0.56	1.00	0.95	0.77	0.58	1.00	0.98	0.80	0.60	1.00	1.00	0.83	0.62	1.00	1.00	0.83	0.62	1.00	1.00	0.83	0.62	1.00	1.00	0.87	0.65
	Δ T	25	24	21	17	26	24	21	17	25	25	21	17	25	25	21	17	23	24	21	17	23	24	21	17	22	22	20	16	22	22	20	16
kW	1.57	1.61	1.66	1.71	1.70	1.73	1.79	1.85	1.81	1.85	1.91	1.98	1.91	1.95	2.02	2.09	1.99	2.03	2.10	2.18	2.06	2.11	2.18	2.26	2.06	2.11	2.18	2.26	2.06	2.11	2.18	2.26	
Amps	6.9	7.1	7.3	7.5	7.4	7.6	7.8	8.1	8.0	8.2	8.4	8.7	8.5	8.7	8.9	9.2	9.0	9.2	9.5	9.8	9.5	9.6	9.9	10.3	9.5	9.7	10.0	10.3	9.5	9.7	10.0	10.3	
HI PR	239	258	272	284	269	289	305	318	306	329	347	362	348	375	396	413	392	421	445	464	433	466	492	513	433	466	492	513	433	466	492	513	
LO PR	113	120	131	140	119	127	139	148	124	132	144	153	130	139	151	161	137	145	159	169	141	150	164	175	141	150	164	175	141	150	164	175	
MBh	21.6	22.0	23.5	25.2	21.1	21.5	23.0	24.6	20.6	21.0	22.4	24.0	20.1	20.5	21.9	23.4	19.1	19.5	20.8	22.2	17.7	18.0	19.3	20.6	17.7	18.0	19.3	20.6	17.7	18.0	19.3	20.6	
S/T	0.92	0.86	0.70	0.52	0.95	0.89	0.73	0.54	0.98	0.92	0.74	0.56	1.01	0.94	0.77	0.57	1.05	0.98	0.80	0.60	1.05	0.99	0.80	0.60	1.05	0.99	0.80	0.60	1.05	0.99	0.80	0.60	
Δ T	26	25	21	17	26	25	22	17	26	25	22	17	26	25	22	17	26	25	22	17	24	23	20	16	24	23	20	16	24	23	20	16	
kW	1.53	1.57	1.62	1.67	1.65	1.69	1.75	1.81	1.76	1.80	1.86	1.93	1.86	1.90	1.96	2.03	1.94	1.98	2.05	2.12	2.01	2.05	2.12	2.20	2.01	2.05	2.12	2.20	2.01	2.05	2.12	2.20	
Amps	6.8	6.9	7.1	7.3	7.2	7.4	7.6	7.9	7.8	8.0	8.2	8.5	8.3	8.5	8.7	9.0	8.7	8.9	9.2	9.5	9.2	9.4	9.7	10.1	9.2	9.4	9.7	10.1	9.2	9.4	9.7	10.1	
HI PR	232	250	264	275	261	280	296	309	296	319	337	351	338	363	384	400	380	409	432	450	420	452	477	497	420	452	477	497	420	452	477	497	
LO PR	110	117	127	136	116	123	134	143	120	128	140	149	126	134	147	156	132	141	154	164	137	146	159	169	137	146	159	169	137	146	159	169	
85	MBh	24.5	25.0	26.1	27.9	23.9	24.4	25.5	27.2	23.3	23.8	24.9	26.6	22.8	23.2	24.3	25.9	21.6	22.1	23.1	24.6	20.0	20.4	21.4	22.8	20.0	20.4	21.4	22.8	20.0	20.4	21.4	22.8
	S/T	1.00	1.00	0.91	0.74	1.00	1.00	0.94	0.77	1.00	1.00	0.97	0.79	1.00	1.00	0.90	0.81	1.00	1.00	0.90	0.84	1.00	1.00	0.90	0.81	1.00	1.00	0.90	0.81	1.00	1.00	0.90	0.81
	Δ T	25	25	24	21	24	25	24	21	24	24	24	21	23	23	23	21	22	22	23	21	20	21	22	20	20	21	22	20	20	21	22	20
	kW	1.60	1.63	1.69	1.74	1.73	1.76	1.82	1.88	1.84	1.88	1.94	2.01	1.94	1.98	2.05	2.12	2.02	2.07	2.14	2.22	2.10	2.15	2.22	2.30	2.10	2.15	2.22	2.30	2.10	2.15	2.22	2.30
	Amps	7.0	7.2	7.4	7.6	7.5	7.7	7.9	8.2	8.1	8.3	8.5	8.8	8.6	8.8	9.1	9.4	9.1	9.3	9.6	10.0	9.6	9.8	10.1	10.5	9.6	9.8	10.1	10.5	9.6	9.8	10.1	10.5
	HI PR	244	263	278	290	274	295	311	325	312	335	354	369	355	382	403	421	399	430	454	473	441	475	501	523	441	475	501	523	441	475	501	523
	LO PR	115	123	134	143	122	130	141	151	127	135	147	157	133	141	154	164	139	148	162	172	144	153	167	178	144	153	167	178	144	153	167	178
	MBh	23.8	24.2	25.4	27.1	23.2	23.7	24.8	26.4	22.7	23.1	24.2	25.8	22.1	22.5	23.6	25.2	21.0	21.4	22.4	23.9	19.5	19.8	20.8	22.2	19.5	19.8	20.8	22.2	19.5	19.8	20.8	22.2
	S/T	1.00	0.96	0.87	0.71	1.00	1.00	0.90	0.73	1.00	1.00	0.92	0.75	1.00	1.00	0.95	0.77	1.00	1.00	0.99	0.80	1.00	1.00	0.99	0.80	1.00	1.00	0.99	0.80	1.00	1.00	0.99	0.80
	Δ T	27	26	25	22	26	27	25	22	26	26	25	22	25	26	26	22	24	24	25	22	22	23	24	20	22	23	24	20	22	23	24	20
kW	1.58	1.62	1.67	1.73	1.71	1.75	1.81	1.87	1.82	1.86	1.93	1.99	1.92	1.97	2.03	2.10	2.01	2.05	2.12	2.20	2.08	2.13	2.20	2.28	2.08	2.13	2.20	2.28	2.08	2.13	2.20	2.28	
Amps	7.0	7.1	7.3	7.6	7.5	7.6	7.9	8.1	8.1	8.2	8.5	8.8	8.6	8.7	9.0	9.3	9.1	9.3	9.5	9.9	9.5	9.8	10.1	10.4	9.5	9.8	10.1	10.4	9.5	9.8	10.1	10.4	
HI PR	242	260	275	287	271	292	308	322	309	332	351	366	352	378	399	417	395	426	449	469	437	470	497	518	437	470	497	518	437	470	497	518	
LO PR	114	121	133	141	121	128	140	149	125	133	146	155	132	140	153	163	138	147	160	171	143	152	166	176	143	152	166	176	143	152	166	176	
MBh	21.9	22.4	23.4	25.0	21.4	21.8	22.9	24.4	20.9	21.3	22.3	23.8	20.4	20.8	21.8	23.2	19.4	19.8	20.7	22.1	18.0	18.3	19.2	20.5	18.0	18.3	19.2	20.5	18.0	18.3	19.2	20.5	
S/T	0.96	0.93	0.84	0.68	1.00	0.96	0.87	0.70	1.00	0.99	0.89	0.72	1.00	1.00	0.92	0.75	1.00	1.00	0.95	0.77	1.00	1.00	0.95	0.77	1.00	1.00	0.95	0.77	1.00	1.00	0.96	0.78	
Δ T	27	27	25	22	28	27	26	22	27	27	26	22	26	27	26	22	25	26	26	22	23	24	24	21	23	24	24	21	23	24	24	21	
kW	1.54	1.58	1.63	1.68	1.67	1.70	1.76	1.82	1.78	1.82	1.88	1.94	1.87	1.92	1.98	2.05	1.95	2.00	2.07	2.14	2.02	2.07	2.14	2.22	2.02	2.07	2.14	2.22	2.02	2.07	2.14	2.22	
Amps	6.8	7.0	7.2	7.4	7.3	7.4	7.7	7.9	7.9	8.0	8.3	8.5	8.3	8.5	8.8	9.1	8.8	9.0	9.3	9.6	9.3	9.5	9.8	10.1	9.3	9.5	9.8	10.1	9.3	9.5	9.8	10.1	
HI PR	235	252	267	278	263	283	299	312	299	322	340	355	341	367	387	404	384	413	436	455	424	456	482	502	424	456	482	502	424	456	482	502	
LO PR	111	118	129	137	117	124	136																										

IDB		OUTDOOR AMBIENT TEMPERATURE																																			
		65						75						85						95						105						115					
		59	63	67	71	71	59	63	67	71	71	59	63	67	71	71	59	63	67	71	71	59	63	67	71	71	59	63	67	71	71	59	63	67	71	71	
70	AIRFLOW	29.7	30.7	33.7	-	29.0	30.0	32.9	-	28.3	29.3	32.1	-	27.6	28.6	31.3	-	26.2	27.2	29.8	-	26.2	27.2	29.8	-	24.3	25.2	27.6	-	24.3	25.2	27.6	-				
	MBh	0.77	0.64	0.44	-	0.80	0.66	0.46	-	0.82	0.68	0.47	-	0.84	0.70	0.49	-	0.87	0.73	0.51	-	0.87	0.73	0.51	-	0.88	0.74	0.51	-	0.88	0.74	0.51	-				
	S/T	20	17	13	-	20	17	13	-	20	17	13	-	20	17	13	-	20	17	13	-	20	17	13	-	19	16	12	-	19	16	12	-				
	Δ T	1.98	2.02	2.08	-	2.13	2.18	2.25	-	2.27	2.32	2.39	-	2.39	2.44	2.52	-	2.49	2.55	2.63	-	2.49	2.55	2.63	-	2.58	2.64	2.73	-	2.58	2.64	2.73	-				
	kW	8.5	8.7	9.0	-	9.1	9.3	9.6	-	9.8	10.0	10.3	-	10.4	10.7	11.0	-	11.0	11.3	11.6	-	11.0	11.3	11.6	-	11.6	11.9	12.2	-	11.6	11.9	12.2	-				
	Amps	238	257	271	-	268	288	304	-	304	327	346	-	347	373	394	-	390	420	443	-	390	420	443	-	431	464	490	-	431	464	490	-				
	HI PR	108	114	125	-	114	121	132	-	118	126	137	-	124	132	144	-	130	138	151	-	130	138	151	-	134	143	156	-	134	143	156	-				
	LO PR	28.8	29.9	32.7	-	28.1	29.2	31.9	-	27.5	28.5	31.2	-	26.8	27.8	30.4	-	25.5	26.4	28.9	-	25.5	26.4	28.9	-	23.6	24.4	26.8	-	23.6	24.4	26.8	-				
	MBh	0.73	0.61	0.42	-	0.76	0.63	0.44	-	0.78	0.65	0.45	-	0.80	0.67	0.46	-	0.83	0.70	0.48	-	0.83	0.70	0.48	-	0.84	0.70	0.49	-	0.84	0.70	0.49	-				
	S/T	20	18	13	-	21	18	14	-	21	18	14	-	21	18	14	-	21	18	14	-	21	18	14	-	19	17	13	-	19	17	13	-				
Δ T	1.96	2.00	2.07	-	2.11	2.16	2.23	-	2.25	2.30	2.37	-	2.37	2.42	2.50	-	2.47	2.53	2.61	-	2.47	2.53	2.61	-	2.56	2.62	2.70	-	2.56	2.62	2.70	-					
kW	8.5	8.7	8.9	-	9.1	9.3	9.5	-	9.8	10.0	10.3	-	10.3	10.6	10.9	-	10.9	11.2	11.5	-	10.9	11.2	11.5	-	11.5	11.8	12.1	-	11.5	11.8	12.1	-					
Amps	236	254	268	-	265	285	301	-	301	324	342	-	343	369	390	-	386	415	439	-	386	415	439	-	427	459	485	-	427	459	485	-					
HI PR	106	113	124	-	112	120	131	-	117	124	136	-	123	131	143	-	129	137	149	-	129	137	149	-	133	142	155	-	133	142	155	-					
LO PR	26.6	27.6	30.2	-	26.0	26.9	29.5	-	25.3	26.3	28.8	-	24.7	25.6	28.1	-	23.5	24.3	26.7	-	23.5	24.3	26.7	-	21.8	22.6	24.7	-	21.8	22.6	24.7	-					
MBh	0.71	0.59	0.41	-	0.73	0.61	0.42	-	0.75	0.63	0.43	-	0.77	0.65	0.45	-	0.80	0.67	0.46	-	0.80	0.67	0.46	-	0.81	0.68	0.47	-	0.81	0.68	0.47	-					
S/T	21	18	14	-	21	18	14	-	21	18	14	-	21	18	14	-	21	18	14	-	21	18	14	-	20	17	13	-	20	17	13	-					
Δ T	1.91	1.95	2.02	-	2.06	2.11	2.17	-	2.19	2.24	2.31	-	2.31	2.36	2.44	-	2.41	2.46	2.54	-	2.41	2.46	2.54	-	2.49	2.55	2.63	-	2.49	2.55	2.63	-					
kW	8.3	8.5	8.7	-	8.9	9.0	9.3	-	9.5	9.7	10.0	-	10.1	10.3	10.6	-	10.7	10.9	11.2	-	10.7	10.9	11.2	-	11.2	11.5	11.8	-	11.2	11.5	11.8	-					
Amps	229	246	260	-	257	277	292	-	292	314	332	-	333	358	378	-	374	403	426	-	374	403	426	-	414	445	470	-	414	445	470	-					
HI PR	103	110	120	-	109	116	127	-	113	121	132	-	119	127	138	-	125	133	145	-	125	133	145	-	129	137	150	-	129	137	150	-					
LO PR																																					

IDB		OUTDOOR AMBIENT TEMPERATURE																																			
		65						75						85						95						105						115					
		59	63	67	71	71	59	63	67	71	71	59	63	67	71	71	59	63	67	71	71	59	63	67	71	71	59	63	67	71	71	59	63	67	71	71	
75	AIRFLOW	30.2	31.1	33.6	36.1	29.5	30.3	32.8	35.2	28.8	29.6	32.1	34.4	28.1	28.9	31.3	33.6	26.7	27.4	29.7	31.9	26.7	27.4	29.7	31.9	24.7	25.4	27.5	29.5	24.7	25.4	27.5	29.5				
	MBh	0.87	0.78	0.59	0.38	0.90	0.81	0.61	0.39	0.93	0.83	0.63	0.40	0.96	0.86	0.65	0.42	0.99	0.89	0.67	0.43	0.99	0.89	0.67	0.43	1.00	0.90	0.68	0.44	1.00	0.90	0.68	0.44				
	S/T	23	21	17	12	23	21	17	12	23	21	17	12	23	21	18	12	23	21	17	12	23	21	17	12	21	20	16	11	21	20	16	11				
	Δ T	1.99	2.04	2.10	2.17	2.15	2.20	2.27	2.34	2.29	2.34	2.42	2.50	2.41	2.46	2.55	2.63	2.51	2.57	2.66	2.75	2.51	2.57	2.66	2.75	2.60	2.66	2.75	2.85	2.60	2.66	2.75	2.85				
	kW	8.6	8.8	9.0	9.3	9.2	9.4	9.7	10.0	9.9	10.1	10.4	10.8	10.5	10.8	11.1	11.4	11.1	11.1	11.4	11.7	12.1	11.1	11.4	11.7	12.1	11.7	12.0	12.3	12.8	11.7	12.0	12.3	12.8			
	Amps	241	259	274	285	270	291	307	320	307	331	349	364	350	377	398	415	394	424	448	467	394	424	448	467	435	468	495	516	435	468	495	516				
	HI PR	109	116	126	134	115	122	133	142	119	127	139	148	125	133	146	155	131	140	152	162	131	140	152	162	136	144	158	168	136	144	158	168				
	LO PR	29.3	30.2	32.6	35.0	28.6	29.5	31.9	34.2	27.9	28.8	31.1	33.4	27.2	28.1	30.4	32.6	25.9	26.6	28.8	31.0	25.9	26.6	28.8	31.0	24.0	24.7	26.7	28.7	24.0	24.7	26.7	28.7				
	MBh	0.83	0.74	0.56	0.36	0.86	0.77	0.58	0.38	0.88	0.79	0.60	0.39	0.91	0.82	0.62	0.40	0.95	0.85	0.64	0.41	0.95	0.85	0.64	0.41	0.96	0.85	0.65	0.42	0.96	0.85	0.65	0.42				
	S/T	24	22	18	12	24	22	18	12	24	22	18	13	24	22	18	13	24	22	18	12	24	22	18	12	22	21	17	12	22	21	17	12				
Δ T	1.98	2.02	2.08	2.15	2.13	2.18	2.25	2.32	2.27	2.32	2.40	2.48	2.39	2.44	2.52	2.61	2.49	2.55	2.63	2.72	2.49	2.55	2.63	2.72	2.58	2.64	2.73	2.82	2.58	2.64	2.73	2.82					
kW	8.5	8.7	9.0	9.3	9.1	9.3	9.6	9.9	9.8	10.0	10.3	10.7	10.4	10.7	11.0	11.4	11.0	11.3	11.6	12.0	11.0	11.3	11.6	12.0	11.6	11.9	12.2	12.7	11.6	11.9	12.2	12.7					
Amps	238	257	271	283	268	288	304	317	304	328	346	361	347	373	394	411	390	420	443	462	390	420	443	462	431	464	490	511	431	464	490	511					
HI PR	108	114	125	133	114	121	132	141	118	126	137	146	124	132	144	153	130	138	151	161	130	138	151	161	134	143	156	166	134	143	156	166					
LO PR	27.0	27.8	30.1	32.3	26.4	27.2	29.4	31.6	25.8	26.5	28.7	30.8	25.1	25.9	28.0	30.1	23.9	24.6	26.6	28.6	23.9	24.6	26.6	28.6	22.1	22.8	24.7	26.5	22.1	22.8	24.7	26.5					
MBh	0.80	0.72	0.54	0.35	0.83	0.74	0.56	0.36	0.85	0.76	0.58	0.37	0.88	0.79	0.60	0.38	0.91	0.82	0.62	0.40	0.91	0.82	0.62	0.40	0.92	0.82	0.62	0.40	0.92	0.82	0.62	0.40					
S/T	24	22	18	13	24	22	18	13	24	22	18	13	24	22	18	13	25	23	19	13	24	22	18	13	23	21	17	12	23	21	17	12					
Δ T	1.93	1.97	2.03	2.10	2.08	2.12	2.19	2.27	2.21	2.26	2.33	2.41	2.33	2.38	2.46	2.54	2.43	2.48	2.57	2.65	2.43	2.48	2.57	2.65	2.51	2.57	2.66	2.75	2.51	2.57	2.66	2.75					
kW	8.4	8.5	8.8	9.0	8.9	9.1	9.4	9.7	9.6	9.8	10.1	10.4	10.2	10.4	10.7	11.1	10.8	11.0	11.3	11.7	10.8	11.0	11.3	11.7	11.3	11.6	11.9	12.3	11.3	11.6	11.9	12.3					
Amps	231	249	263	274	260	279	295	308	295	318	335	350	336	362	382	399	378	407	430	448	378	407	430	448	418	450	475	495	418	450	475	495					
HI PR	104	111	121	129	110	117	128	136	115	122	133	142	120	128	140	149	126	134	146	156	126	134	146	156	130	139	151	161	130	139	151	161					
LO PR																																					

IDB: Entering Indoor Dry Bulb Temperature
 High and low pressures are measured at the liquid and suction service valves.

IDB		OUTDOOR AMBIENT TEMPERATURE																																		
		65					75					85					95					105					115									
		59	63	67	71	75	59	63	67	71	75	59	63	67	71	75	59	63	67	71	75	59	63	67	71	75	59	63	67	71	75					
		ENTERING INDOOR WET BULB TEMPERATURE																																		
AIRFLOW		59	63	67	71	75	59	63	67	71	75	59	63	67	71	75	59	63	67	71	75	59	63	67	71	75	59	63	67	71	75	59	63	67	71	75
1062	MBh	30.7	31.4	33.5	35.8	35.0	30.0	30.6	32.7	35.0	34.2	29.3	29.9	32.0	34.2	33.3	28.6	29.2	31.2	33.3	33.3	27.1	27.7	29.6	31.7	31.7	25.1	25.7	27.4	29.3	29.3					
	S/T	0.96	0.90	0.73	0.55	0.57	1.00	0.93	0.76	0.57	0.58	1.00	0.95	0.78	0.58	0.60	1.00	1.00	0.80	0.60	0.60	1.00	1.00	0.83	0.62	0.62	1.00	1.00	0.84	0.63	0.63					
	Δ T	25	24	21	17	17	26	25	21	17	17	25	25	21	17	17	25	25	25	25	25	23	24	21	17	17	22	22	20	16	16					
	kW	2.01	2.05	2.12	2.19	2.36	2.17	2.21	2.29	2.36	2.52	2.31	2.36	2.44	2.52	2.65	2.43	2.48	2.57	2.65	2.65	2.53	2.59	2.68	2.77	2.77	2.62	2.68	2.78	2.87	2.87					
	Amps	8.7	8.9	9.1	9.4	9.9	9.3	9.5	9.8	10.1	10.9	10.0	10.2	10.5	10.9	11.5	10.6	10.8	11.2	11.5	11.5	11.2	11.5	11.8	12.2	12.2	11.8	12.1	12.5	12.9	12.9					
80	HI PR	243	262	276	288	324	273	294	310	324	368	311	334	353	368	419	354	381	402	419	419	398	428	452	472	472	440	473	500	521	521					
	LO PR	110	117	127	136	143	116	123	135	143	149	120	128	140	149	157	127	135	147	157	157	133	141	154	164	164	137	146	159	170	170					
	MBh	29.8	30.5	32.5	34.8	34.0	29.1	29.8	31.8	34.0	33.2	28.4	29.0	31.0	33.2	32.4	27.7	28.3	30.3	32.4	32.4	26.3	26.9	28.8	30.7	30.7	24.4	24.9	26.6	28.5	28.5					
	S/T	0.91	0.86	0.70	0.52	0.54	0.95	0.89	0.72	0.54	0.55	0.97	0.91	0.74	0.55	0.57	1.00	0.94	0.76	0.57	0.57	1.00	0.97	0.79	0.59	0.59	1.00	0.98	0.80	0.60	0.60					
	Δ T	26	25	22	18	18	27	26	22	18	18	27	26	22	18	18	27	26	22	18	18	26	25	22	18	18	24	24	21	17	17					
830	kW	1.99	2.04	2.10	2.17	2.34	2.15	2.20	2.27	2.34	2.50	2.29	2.34	2.42	2.50	2.63	2.41	2.46	2.55	2.63	2.63	2.51	2.57	2.66	2.75	2.75	2.60	2.66	2.75	2.85	2.85					
	Amps	8.6	8.8	9.0	9.3	9.9	9.2	9.4	9.7	10.0	10.8	9.9	10.1	10.4	10.8	11.4	10.5	10.8	11.1	11.4	11.4	11.1	11.4	11.7	12.1	12.1	11.7	12.0	12.3	12.8	12.8					
	HI PR	241	259	274	286	320	270	291	307	320	364	307	331	349	364	415	350	377	398	415	415	394	424	448	467	467	435	468	495	516	516					
	LO PR	109	116	126	134	142	115	122	133	142	148	119	127	139	148	155	125	133	146	155	155	131	140	153	162	162	136	144	158	168	168					
	MBh	27.5	28.1	30.0	32.1	31.4	26.9	27.5	29.3	31.4	30.6	26.2	26.8	28.6	30.6	29.9	25.6	26.2	27.9	29.9	29.9	24.3	24.8	26.5	28.4	28.4	22.5	23.0	24.6	26.3	26.3					
85	S/T	0.88	0.83	0.67	0.50	0.52	0.91	0.86	0.70	0.52	0.53	0.94	0.88	0.71	0.53	0.55	0.97	0.91	0.74	0.55	0.55	1.00	0.94	0.76	0.57	0.57	1.01	0.95	0.77	0.58	0.58					
	Δ T	27	26	22	18	18	27	26	23	18	18	27	26	23	18	18	27	26	23	18	18	27	26	22	18	18	25	24	21	17	17					
	kW	1.94	1.99	2.05	2.12	2.28	2.10	2.14	2.21	2.28	2.43	2.23	2.28	2.35	2.43	2.56	2.35	2.40	2.48	2.56	2.56	2.45	2.50	2.59	2.68	2.68	2.54	2.59	2.68	2.77	2.77					
	Amps	8.4	8.6	8.8	9.1	9.8	9.0	9.2	9.5	9.8	10.5	9.7	9.9	10.2	10.5	11.2	10.3	10.5	10.8	11.2	11.2	10.8	11.1	11.4	11.8	11.8	11.4	11.7	12.0	12.4	12.4					
	HI PR	234	251	266	277	311	262	282	298	311	353	298	321	339	353	403	340	366	386	403	403	382	411	434	453	453	422	454	480	500	500					
1062	LO PR	105	112	122	130	138	111	118	129	138	143	116	123	134	143	150	122	129	141	150	150	127	136	148	158	158	132	140	153	163	163					
	MBh	31.2	31.8	33.4	35.6	34.8	30.5	31.1	32.6	34.8	33.9	29.8	30.4	31.8	33.9	33.1	29.1	29.6	31.0	33.1	33.1	27.6	28.1	29.5	31.4	31.4	25.6	26.1	27.3	29.1	29.1					
	S/T	1.00	0.97	0.87	0.71	0.73	1.00	1.00	0.91	0.73	0.75	1.00	1.00	0.93	0.75	0.78	1.00	1.00	0.96	0.78	0.78	1.00	1.00	0.99	0.81	0.81	1.00	1.00	1.00	0.81	0.81					
	Δ T	27	27	25	22	22	26	27	26	22	22	26	26	26	22	22	25	26	26	22	22	24	24	25	22	22	22	23	24	21	21					
	kW	2.03	2.07	2.14	2.21	2.38	2.18	2.23	2.31	2.38	2.54	2.33	2.38	2.46	2.54	2.68	2.45	2.51	2.59	2.68	2.68	2.56	2.61	2.70	2.79	2.79	2.65	2.71	2.80	2.90	2.90					
946	Amps	8.8	8.9	9.2	9.5	10.2	9.4	9.6	9.8	10.2	11.0	10.1	10.3	10.6	11.0	11.6	10.7	10.9	11.3	11.6	11.6	11.3	11.6	11.9	12.3	12.3	11.9	12.2	12.6	13.0	13.0					
	HI PR	246	264	279	291	327	276	297	313	327	372	314	337	356	372	423	357	384	406	423	423	402	432	457	476	476	444	478	505	526	526					
	LO PR	111	118	129	137	145	117	125	136	145	151	122	129	141	151	158	128	136	148	158	158	134	143	156	166	166	139	147	161	171	171					
	MBh	30.3	30.9	32.4	34.5	33.7	29.6	30.2	31.6	33.7	32.9	28.9	29.5	30.9	32.9	32.1	28.2	28.8	30.1	32.1	32.1	26.8	27.3	28.6	30.5	30.5	24.8	25.3	26.5	28.3	28.3					
	S/T	0.96	0.92	0.83	0.68	0.70	0.99	0.96	0.86	0.70	0.72	1.00	0.98	0.89	0.72	0.74	1.00	1.00	0.91	0.74	0.74	1.00	1.00	0.95	0.77	0.77	1.00	1.00	0.96	0.78	0.78					
830	Δ T	28	28	26	23	23	29	28	27	23	23	28	28	27	23	23	27	28	27	23	23	26	27	26	23	23	24	25	25	21	21					
	kW	2.01	2.05	2.12	2.19	2.36	2.17	2.21	2.29	2.36	2.52	2.31	2.36	2.44	2.52	2.65	2.43	2.48	2.57	2.65	2.65	2.53	2.59	2.68	2.77	2.77	2.62	2.68	2.78	2.87	2.87					
	Amps	8.7	8.9	9.1	9.4	10.1	9.3	9.5	9.8	10.1	10.9	10.0	10.2	10.5	10.9	11.5	10.6	10.8	11.2	11.5	11.5	11.2	11.5	11.8	12.2	12.2	11.8	12.1	12.5	12.9	12.9					
	HI PR	243	262	276	288	324	273	294	310	324	368	311	334	353	368	419	354	381	402	419	419	398	428	452	472	472	440	473	500	521	521					
	LO PR	110	117	127	136	143	116	123	135	143	149	120	128	140	149	157	127	135	147	157	157	133	141	154	164	164	137	146	159	170	170					
85	MBh	28.0	28.5	29.9	31.9	31.1	27.3	27.9	29.2	31.1	30.4	26.7	27.2	28.5	30.4	29.7	26.0	26.5	27.8	29.7	29.7	24.7	25.2	26.4	28.2	28.2	22.9	23.4	24.5	26.1	26.1					
	S/T	0.92	0.89	0.80	0.65	0.68	0.96	0.92	0.83	0.68	0.69	0.98	0.95	0.85	0.69	0.72	1.00	0.98	0.88	0.72	0.72	1.00	1.00	0.91	0.74	0.74	1.00	1.00	0.92	0.75	0.75					
	Δ T	29	28	27	23	23	29	28	27	23	23	29	29	27	23	23	29	29	27	23	23	27	28	27	23	23	25	26	25	22	22					
	kW	1.96	2.00	2.07	2.13	2.30	2.11	2.16	2.23	2.30	2.45	2.25	2.30	2.37	2.45	2.59	2.37	2.42	2.50	2.59	2.59	2.47	2.52	2.61	2.70	2.70	2.56	2.61	2.70	2.80	2.80					
	Amps	8.5	8.7	8.9	9.2	9.8	9.1	9.3	9.5	9.8	10.6	9.8	10.0	10.3	10.6	11.3	10.3	10.6	10.9	11.3	11.3	10.9	11.2	11.5	11.9	11.9	11.5	11.8	12.1	12.6	12.6					
1062	HI PR	236	254	268	280	314	265	285	301	314	357	301	324	342	357	407	343	369	390	407	407	386	415	439	457	457	426	459	485	505	505					
	LO PR	106	113	124	132	139	112	120	131	139	145	117	124	136	145	152	123	131	143	152	152	129	137	149	159	159	133	142	155	165	165					

IDB: Entering Indoor Dry Bulb Temperature
 High and low pressures are measured at the liquid and suction service valves.
 Shaded area reflects AHRI (TVA) conditions
 kW = Total system power
 Amps =

IDB		OUTDOOR AMBIENT TEMPERATURE																							
		65				75				85				95				105				115			
		59	63	67	71	59	63	67	71	59	63	67	71	59	63	67	71	59	63	67	71	59	63	67	71
70	AIRFLOW	59	63	67	71	59	63	67	71	59	63	67	71	59	63	67	71	59	63	67	71	59	63	67	71
	MBh	36.4	37.7	41.3	-	35.5	36.8	40.3	-	34.7	35.9	39.4	-	33.8	35.1	38.4	-	32.1	33.3	36.5	-	32.1	33.3	36.5	-
	S/T	0.80	0.67	0.46	-	0.83	0.69	0.48	-	0.85	0.71	0.49	-	0.88	0.73	0.51	-	0.91	0.76	0.53	-	0.91	0.76	0.53	-
	Δ T	20	17	13	-	20	17	13	-	20	17	13	-	20	17	13	-	20	17	13	-	20	17	13	-
	kW	2.42	2.47	2.54	-	2.60	2.66	2.74	-	2.77	2.83	2.92	-	2.91	2.97	3.07	-	3.03	3.10	3.20	-	3.03	3.10	3.20	-
	Amps	11.1	11.4	11.7	-	11.9	12.1	12.4	-	12.7	13.0	13.3	-	13.4	13.7	14.1	-	14.2	14.5	14.9	-	14.2	14.5	14.9	-
	HI PR	224	241	254	-	251	270	285	-	286	307	325	-	325	350	370	-	366	394	416	-	366	394	416	-
	LO PR	112	119	130	-	118	126	137	-	123	131	143	-	129	137	150	-	135	144	157	-	135	144	157	-
	MBh	35.3	36.6	40.1	-	34.5	35.8	39.2	-	33.7	34.9	38.2	-	32.8	34.0	37.3	-	31.2	32.3	35.4	-	31.2	32.3	35.4	-
	S/T	0.76	0.64	0.44	-	0.79	0.66	0.46	-	0.81	0.68	0.47	-	0.84	0.70	0.48	-	0.87	0.72	0.50	-	0.87	0.72	0.50	-
Δ T	20	18	13	-	21	18	14	-	21	18	14	-	21	18	14	-	20	18	13	-	20	18	13	-	
kW	2.40	2.45	2.52	-	2.58	2.64	2.72	-	2.74	2.80	2.89	-	2.89	2.95	3.05	-	3.01	3.07	3.18	-	3.01	3.07	3.18	-	
Amps	11.1	11.3	11.6	-	11.8	12.0	12.3	-	12.6	12.9	13.2	-	13.3	13.6	14.0	-	14.1	14.3	14.8	-	14.1	14.3	14.8	-	
HI PR	222	238	252	-	249	268	283	-	283	304	321	-	322	347	366	-	362	390	412	-	362	390	412	-	
LO PR	111	118	129	-	117	125	136	-	122	129	141	-	128	136	148	-	134	143	156	-	134	143	156	-	
MBh	32.6	33.8	37.0	-	31.8	33.0	36.2	-	31.1	32.2	35.3	-	30.3	31.4	34.4	-	28.8	29.9	32.7	-	28.8	29.9	32.7	-	
S/T	0.73	0.61	0.42	-	0.76	0.64	0.44	-	0.78	0.65	0.45	-	0.81	0.67	0.47	-	0.84	0.70	0.48	-	0.84	0.70	0.48	-	
Δ T	21	18	14	-	21	18	14	-	21	18	14	-	21	18	14	-	21	18	14	-	21	18	14	-	
kW	2.34	2.39	2.46	-	2.52	2.57	2.65	-	2.68	2.73	2.82	-	2.81	2.88	2.97	-	2.93	3.00	3.10	-	2.93	3.00	3.10	-	
Amps	10.8	11.0	11.3	-	11.5	11.7	12.1	-	12.3	12.6	12.9	-	13.0	13.3	13.7	-	13.7	14.0	14.4	-	13.7	14.0	14.4	-	
HI PR	215	231	244	-	241	260	274	-	274	295	312	-	312	336	355	-	351	378	399	-	351	378	399	-	
LO PR	108	114	125	-	114	121	132	-	118	126	137	-	124	132	144	-	130	138	151	-	130	138	151	-	

IDB		OUTDOOR AMBIENT TEMPERATURE																							
		65				75				85				95				105				115			
		59	63	67	71	59	63	67	71	59	63	67	71	59	63	67	71	59	63	67	71	59	63	67	71
75	AIRFLOW	59	63	67	71	59	63	67	71	59	63	67	71	59	63	67	71	59	63	67	71	59	63	67	71
	MBh	37.0	38.1	41.2	44.2	36.1	37.2	40.3	43.2	35.3	36.3	39.3	42.2	34.4	35.4	38.3	41.2	32.7	33.7	36.4	39.1	32.7	33.7	36.4	39.1
	S/T	0.91	0.81	0.61	0.40	0.94	0.84	0.64	0.41	0.96	0.86	0.65	0.42	1.00	0.89	0.67	0.43	1.00	0.92	0.70	0.45	1.00	0.92	0.70	0.45
	Δ T	23	21	17	12	23	21	17	12	23	21	17	12	23	21	17	12	22	21	17	12	22	21	17	12
	kW	2.44	2.49	2.57	2.65	2.62	2.68	2.77	2.86	2.79	2.85	2.94	3.04	2.93	3.00	3.10	3.20	3.06	3.13	3.23	3.34	3.06	3.13	3.23	3.34
	Amps	11.2	11.4	11.7	12.1	12.0	12.2	12.5	12.9	12.8	13.1	13.4	13.9	13.5	13.8	14.2	14.7	14.3	14.6	15.0	15.5	14.3	14.6	15.0	15.5
	HI PR	226	243	257	268	254	273	288	301	289	311	328	342	329	354	373	390	370	398	420	438	370	398	420	438
	LO PR	113	120	131	140	119	127	139	148	124	132	144	154	130	139	152	161	137	145	159	169	137	145	159	169
	MBh	35.9	37.0	40.0	43.0	35.1	36.1	39.1	42.0	34.2	35.3	38.2	41.0	33.4	34.4	37.2	40.0	31.7	32.7	35.4	38.0	31.7	32.7	35.4	38.0
	S/T	0.87	0.77	0.59	0.38	0.90	0.80	0.61	0.39	0.92	0.82	0.62	0.40	0.95	0.85	0.64	0.41	0.99	0.88	0.67	0.43	0.99	0.88	0.67	0.43
Δ T	23	22	18	12	24	22	18	12	24	22	18	12	24	22	18	12	24	22	18	12	24	22	18	12	
kW	2.42	2.47	2.55	2.63	2.60	2.66	2.74	2.83	2.77	2.83	2.92	3.01	2.91	2.97	3.07	3.17	3.03	3.10	3.20	3.31	3.03	3.10	3.20	3.31	
Amps	11.1	11.4	11.7	12.0	11.9	12.1	12.4	12.8	12.7	13.0	13.3	13.7	13.4	13.7	14.1	14.6	14.2	14.5	14.9	15.4	14.2	14.5	14.9	15.4	
HI PR	224	241	254	265	251	270	285	298	286	307	325	339	325	350	370	386	366	394	416	434	366	394	416	434	
LO PR	112	119	130	139	118	126	137	146	123	131	143	152	129	137	150	160	135	144	157	167	135	144	157	167	
MBh	33.1	34.1	36.9	39.6	32.4	33.3	36.1	38.7	31.6	32.5	35.2	37.8	30.8	31.7	34.4	36.9	29.3	30.2	32.6	35.0	29.3	30.2	32.6	35.0	
S/T	0.83	0.75	0.57	0.36	0.87	0.77	0.59	0.38	0.89	0.79	0.60	0.39	0.92	0.82	0.62	0.40	0.95	0.85	0.64	0.41	0.95	0.85	0.64	0.41	
Δ T	24	22	18	12	24	22	18	13	24	22	18	13	24	22	18	13	24	22	18	12	24	22	18	12	
kW	2.36	2.41	2.48	2.56	2.54	2.59	2.68	2.76	2.70	2.76	2.85	2.94	2.84	2.90	2.99	3.09	2.96	3.02	3.12	3.23	2.96	3.02	3.12	3.23	
Amps	10.9	11.1	11.4	11.7	11.6	11.8	12.2	12.5	12.4	12.7	13.0	13.4	13.1	13.4	13.8	14.2	13.8	14.1	14.5	15.0	13.8	14.1	14.5	15.0	
HI PR	217	234	247	257	244	262	277	289	277	298	315	328	316	340	359	374	355	382	404	421	355	382	404	421	
LO PR	109	116	126	134	115	122	133	142	119	127	139	148	125	133	146	155	131	140	152	162	131	140	152	162	

IDB: Entering Indoor Dry Bulb Temperature
 High and low pressures are measured at the liquid and suction service valves.
 Shaded area reflects ACCA (TVA) conditions
 kW = Total system power
 Amps = outdoor unit amps (comp.+fan)

IDB		OUTDOOR AMBIENT TEMPERATURE																													
		65					75					85					95					105					115				
		59	63	67	71	75	59	63	67	71	75	59	63	67	71	75	59	63	67	71	75	59	63	67	71	75	59	63	67	71	75
AIRFLOW		59	63	67	71	75	59	63	67	71	75	59	63	67	71	75	59	63	67	71	75	59	63	67	71	75	59	63	67	71	75
80	MBh	37.6	38.5	41.1	43.9	46.7	36.8	37.6	40.1	42.9	45.7	35.9	36.7	39.2	41.9	44.7	35.0	35.8	38.2	40.9	43.7	33.3	34.0	36.3	38.8	41.6	30.8	31.5	33.6	36.0	38.4
	S/T	1.00	0.93	0.76	0.57	0.38	1.00	0.97	0.79	0.59	0.40	1.00	1.00	0.81	0.60	0.41	1.00	1.00	0.83	0.62	0.42	1.00	1.00	0.87	0.65	0.44	1.00	1.00	0.87	0.65	0.44
	Δ T	25	24	21	17	13	25	24	21	17	13	24	25	21	17	13	24	24	21	17	13	22	23	21	17	13	21	21	20	16	12
	kW	2.46	2.51	2.59	2.67	2.75	2.64	2.70	2.79	2.88	2.96	2.81	2.87	2.97	3.07	3.16	2.96	3.02	3.12	3.23	3.34	3.08	3.15	3.26	3.37	3.49	3.19	3.26	3.37	3.49	3.61
	Amps	11.3	11.5	11.8	12.2	12.6	12.0	12.3	12.6	13.0	13.4	12.9	13.2	13.5	14.0	14.4	13.6	13.9	14.3	14.8	15.2	14.4	14.7	15.1	15.6	16.0	15.1	15.4	15.9	16.4	16.8
	HI PR	228	246	260	271	281	256	276	291	304	314	291	314	331	345	354	332	357	377	393	402	373	402	424	443	453	413	444	469	489	500
	LO PR	114	122	133	141	149	121	128	140	149	155	125	133	146	155	163	132	140	153	163	171	138	147	160	171	179	143	152	166	177	185
	MBh	36.6	37.3	39.9	42.7	45.5	35.7	36.5	39.0	41.7	44.5	34.9	35.6	38.0	40.7	43.5	34.0	34.7	37.1	39.7	42.5	32.3	33.0	35.3	37.7	40.1	29.9	30.6	32.7	34.9	37.1
	S/T	0.95	0.89	0.72	0.54	0.36	0.98	0.92	0.75	0.56	0.38	1.00	0.95	0.77	0.58	0.40	1.00	0.98	0.80	0.59	0.41	1.00	1.00	0.83	0.62	0.43	1.00	1.00	0.83	0.62	0.43
	Δ T	26	25	22	17	13	27	25	22	18	14	26	25	22	18	14	26	26	22	18	14	24	25	22	18	14	23	23	21	16	12
kW	2.44	2.49	2.57	2.65	2.73	2.62	2.68	2.77	2.86	2.94	2.79	2.85	2.94	3.04	3.13	2.93	3.00	3.10	3.20	3.30	3.06	3.13	3.23	3.34	3.44	3.17	3.24	3.34	3.46	3.57	
Amps	11.2	11.4	11.7	12.1	12.5	12.0	12.2	12.5	12.9	13.3	12.8	13.1	13.4	13.9	14.3	13.5	13.8	14.2	14.7	15.1	14.3	14.6	15.0	15.5	15.9	15.0	15.3	15.8	16.3	16.7	
HI PR	226	243	257	268	278	254	273	288	301	311	289	311	328	342	351	329	354	374	390	400	370	398	420	438	448	409	440	464	484	500	
LO PR	113	120	131	140	148	120	127	139	148	154	124	132	144	154	161	130	139	152	161	169	137	145	159	169	175	141	150	164	175	181	
MBh	33.7	34.5	36.8	39.4	42.0	33.0	33.7	36.0	38.5	41.1	32.2	32.9	35.1	37.5	40.1	31.4	32.1	34.3	36.6	39.2	29.8	30.5	32.5	34.8	37.1	27.6	28.2	30.1	32.2	34.2	
S/T	0.92	0.86	0.70	0.52	0.34	0.95	0.89	0.72	0.54	0.36	0.97	0.91	0.74	0.56	0.38	1.00	0.94	0.77	0.57	0.39	1.04	0.98	0.80	0.59	0.41	1.05	0.99	0.80	0.60	0.42	
Δ T	27	26	22	18	14	27	26	22	18	14	27	26	22	18	14	27	26	23	18	14	27	26	22	18	14	25	24	21	17	13	
kW	2.38	2.43	2.50	2.58	2.66	2.56	2.61	2.70	2.79	2.87	2.72	2.78	2.87	2.96	3.04	2.86	2.92	3.02	3.12	3.21	2.98	3.05	3.15	3.25	3.34	3.09	3.15	3.26	3.37	3.47	
Amps	11.0	11.2	11.5	11.8	12.2	11.7	11.9	12.2	12.6	12.9	12.5	12.8	13.1	13.5	13.9	13.2	13.5	13.9	14.3	14.7	13.9	14.2	14.6	15.1	15.5	14.6	15.0	15.4	15.9	16.3	
HI PR	219	236	249	260	270	246	265	280	292	302	280	301	318	332	341	319	343	362	378	387	359	386	408	425	434	396	426	450	470	489	
LO PR	110	117	127	136	144	116	123	135	143	150	120	128	140	149	157	127	135	147	157	165	133	141	154	164	171	137	146	159	170	177	
85	MBh	38.3	39.0	40.9	43.6	46.3	37.4	38.1	39.9	42.6	45.3	36.5	37.2	39.0	41.6	44.3	35.6	36.3	38.0	40.6	43.3	33.9	34.5	36.1	38.6	41.1	31.4	32.0	33.5	35.7	37.9
	S/T	1.00	1.00	0.91	0.74	0.56	1.00	1.00	0.94	0.76	0.58	1.00	1.00	0.97	0.78	0.60	1.00	1.00	1.00	0.81	0.63	1.00	1.00	1.00	0.84	0.66	1.00	1.00	1.00	0.85	0.67
	Δ T	26	26	25	22	18	25	26	25	22	18	25	25	25	22	18	24	24	26	22	18	23	23	24	22	18	21	22	23	20	16
	kW	2.47	2.53	2.61	2.69	2.77	2.67	2.72	2.81	2.90	2.98	2.83	2.90	2.99	3.09	3.17	2.98	3.05	3.15	3.26	3.34	3.11	3.18	3.29	3.40	3.49	3.22	3.29	3.40	3.52	3.63
	Amps	11.4	11.6	11.9	12.3	12.7	12.1	12.4	12.7	13.1	13.4	13.0	13.3	13.6	14.1	14.4	13.8	14.0	14.4	14.9	15.2	14.5	14.8	15.2	15.7	16.0	15.2	15.6	16.0	16.5	16.8
	HI PR	231	248	262	273	283	259	279	294	307	317	294	317	335	349	359	335	361	381	397	407	377	406	429	447	457	417	448	474	494	514
	LO PR	115	123	134	143	151	122	130	142	151	159	127	135	147	157	165	133	142	155	165	173	139	148	162	173	181	144	153	168	178	186
	MBh	37.2	37.9	39.7	42.4	45.1	36.3	37.0	38.8	41.4	44.1	35.5	36.1	37.9	40.4	43.1	34.6	35.3	36.9	39.4	42.1	32.9	33.5	35.1	37.4	40.1	30.4	31.0	32.5	34.7	36.9
	S/T	1.00	0.96	0.87	0.70	0.52	1.00	1.00	0.90	0.73	0.55	1.00	1.00	0.92	0.75	0.57	1.00	1.00	0.95	0.77	0.59	1.00	1.00	0.99	0.80	0.62	1.00	1.00	1.00	0.81	0.63
	Δ T	28	28	26	23	19	27	28	26	23	19	27	27	26	23	19	26	27	27	23	19	25	25	26	23	19	23	23	24	21	17
kW	2.46	2.51	2.59	2.67	2.75	2.64	2.70	2.79	2.88	2.96	2.81	2.87	2.97	3.07	3.15	2.96	3.02	3.12	3.23	3.31	3.08	3.15	3.26	3.37	3.45	3.19	3.26	3.37	3.49	3.60	
Amps	11.3	11.5	11.8	12.2	12.6	12.0	12.3	12.6	13.0	13.3	12.9	13.2	13.5	14.0	14.3	13.6	13.9	14.3	14.8	15.1	14.4	14.7	15.1	15.6	15.9	15.1	15.4	15.9	16.4	16.7	
HI PR	228	246	260	271	281	256	276	291	304	314	291	314	331	345	354	332	357	377	393	402	373	402	424	443	453	413	444	469	489	500	
LO PR	114	122	133	141	149	121	128	140	149	155	125	133	146	155	163	132	140	153	163	171	138	147	160	171	179	143	152	166	177	185	
MBh	34.3	35.0	36.6	39.1	41.7	33.5	34.2	35.8	38.2	40.8	32.7	33.4	34.9	37.3	39.9	31.9	32.5	34.1	36.4	39.0	30.3	30.9	32.4	34.5	37.1	28.1	28.6	30.0	32.0	34.0	
S/T	0.96	0.93	0.84	0.68	0.50	0.99	0.96	0.87	0.70	0.52	1.00	0.98	0.89	0.72	0.54	1.00	1.00	0.92	0.74	0.56	1.00	1.00	0.95	0.77	0.59	1.00	1.00	0.96	0.78	0.60	
Δ T	28	28	26	23	19	29	28	27	23	19	28	28	27	23	19	28	28	27	23	19	26	27	27	23	19	24	25	25	21	17	
kW	2.40	2.45	2.52	2.60	2.68	2.58	2.64	2.72	2.81	2.89	2.74	2.80	2.89	2.99	3.07	2.89	2.95	3.05	3.15	3.23	3.01	3.07	3.17	3.28	3.36	3.11	3.18	3.29	3.40	3.50	
Amps	11.1	11.3	11.6	11.9	12.3	11.8	12.0	12.3	12.7	13.0	12.6	12.9	13.2	13.6	14.0	13.3	13.6	14.0	14.4	14.8	14.0	14.3	14.8	15.2	15.6	14.8	15.1	15.5	16.0	16.3	
HI PR	222	238	252	263	273	249	268	282	295	305	283	304	321	335	345	322	347	366	382	392	362	390	412	429	439	400	431	455	474	494	
LO PR	111	118	129	137	145	117	125	136	145	153	122	129	141	151	159	128	136	148	158	166	134	143	156	166	174	139	147	161	171	179	

IDB: Entering Indoor Dry Bulb Temperature
 High and low pressures are measured at the liquid and suction service valves.
 Shaded area reflects AHRI (TVA) conditions
 kW = Total system power
 Amps = outdoor unit amps (comp.+fan)

IDB		OUTDOOR AMBIENT TEMPERATURE												ENTERING INDOOR WET BULB TEMPERATURE											
		65				75				85				95				105				115			
		59	63	67	71	59	63	67	71	59	63	67	71	59	63	67	71	59	63	67	71	59	63	67	71
80	MBh	44.3	45.2	48.3	51.6	43.2	44.2	47.2	50.4	42.2	43.1	46.1	49.2	41.2	42.1	44.9	48.0	39.1	40.0	42.7	45.6	36.2	37.0	39.5	42.3
	S/T	0.93	0.87	0.71	0.53	0.96	0.90	0.74	0.55	1.00	0.93	0.75	0.56	1.00	0.96	0.78	0.58	1.00	1.00	0.81	0.60	1.00	1.00	0.82	0.61
	Δ T	27	26	22	18	27	26	23	18	28	26	23	18	27	26	23	18	26	26	23	18	24	24	21	17
	kW	2.81	2.87	2.96	3.05	3.03	3.09	3.19	3.30	3.22	3.29	3.40	3.51	3.39	3.46	3.58	3.70	3.53	3.61	3.73	3.86	3.65	3.74	3.86	3.99
	Amps	12.4	12.6	13.0	13.4	13.2	13.5	13.9	14.3	14.2	14.5	14.9	15.4	15.1	15.4	15.8	16.4	15.9	16.3	16.7	17.3	16.7	17.1	17.6	18.2
	HI PR	244	262	277	289	274	294	311	324	311	335	354	369	354	381	403	420	399	429	453	473	441	474	501	522
	LO PR	111	118	129	137	117	125	136	145	122	130	142	151	128	136	149	158	134	143	156	166	139	148	161	172
	MBh	43.0	43.9	46.9	50.1	42.0	42.9	45.8	49.0	41.0	41.9	44.7	47.8	40.0	40.8	43.6	46.6	38.0	38.8	41.4	44.3	35.2	35.9	38.4	41.0
	S/T	0.89	0.83	0.68	0.51	0.92	0.86	0.70	0.52	0.94	0.88	0.72	0.54	0.97	0.91	0.74	0.56	1.00	0.95	0.77	0.58	1.00	0.96	0.78	0.58
	Δ T	28	27	23	19	28	27	24	19	28	27	24	19	28	27	24	19	28	27	23	19	26	25	22	17
kW	2.79	2.85	2.94	3.03	3.00	3.07	3.16	3.27	3.19	3.26	3.37	3.48	3.36	3.43	3.55	3.67	3.50	3.58	3.70	3.82	3.62	3.71	3.83	3.96	
Amps	12.3	12.5	12.9	13.3	13.1	13.4	13.8	14.2	14.1	14.4	14.8	15.3	14.9	15.3	15.7	16.2	15.8	16.1	16.6	17.2	16.6	17.0	17.5	18.1	
HI PR	241	260	274	286	271	292	308	321	308	332	350	365	351	378	399	416	395	425	449	468	436	469	496	517	
LO PR	110	117	128	136	116	124	135	144	121	128	140	149	127	135	147	157	133	141	154	164	137	146	160	170	
MBh	39.7	40.5	43.3	46.3	38.7	39.6	42.3	45.2	37.8	38.6	41.3	44.1	36.9	37.7	40.3	43.1	35.0	35.8	38.3	40.9	32.5	33.2	35.4	37.9	
S/T	0.86	0.80	0.65	0.49	0.89	0.83	0.68	0.51	0.91	0.85	0.69	0.52	0.94	0.88	0.72	0.54	0.97	0.91	0.74	0.56	0.98	0.92	0.75	0.56	
Δ T	28	27	24	19	29	27	24	19	29	28	24	19	29	28	24	19	28	27	24	19	27	26	22	18	
kW	2.72	2.78	2.86	2.96	2.93	2.99	3.09	3.19	3.11	3.18	3.28	3.39	3.27	3.35	3.46	3.57	3.41	3.49	3.60	3.73	3.53	3.61	3.73	3.86	
Amps	12.0	12.2	12.6	13.0	12.8	13.1	13.4	13.9	13.8	14.0	14.5	14.9	14.6	14.9	15.3	15.8	15.4	15.7	16.2	16.7	16.2	16.6	17.1	17.6	
HI PR	234	252	266	278	263	283	299	311	299	322	340	354	340	366	387	403	383	412	435	454	423	455	481	501	
LO PR	107	113	124	132	113	120	131	139	117	125	136	145	123	131	143	152	129	137	150	159	133	142	155	165	
85	MBh	45.0	45.9	48.1	51.3	44.0	44.8	47.0	50.1	42.9	43.8	45.8	48.9	41.9	42.7	44.7	47.7	39.8	40.6	42.5	45.3	36.9	37.6	39.3	42.0
	S/T	0.98	0.94	0.85	0.69	1.00	0.98	0.88	0.71	1.00	1.00	0.90	0.73	1.00	1.00	0.93	0.76	1.00	1.00	0.97	0.78	1.00	1.00	0.98	0.79
	Δ T	29	28	27	23	29	29	27	23	28	29	27	23	27	28	27	24	26	26	27	23	24	25	25	22
	kW	2.83	2.89	2.98	3.08	3.05	3.12	3.22	3.32	3.24	3.32	3.42	3.54	3.41	3.49	3.61	3.73	3.56	3.64	3.76	3.89	3.68	3.77	3.89	4.03
	Amps	12.5	12.7	13.1	13.5	13.3	13.6	14.0	14.4	14.3	14.6	15.0	15.5	15.2	15.5	16.0	16.5	16.0	16.4	16.9	17.5	16.9	17.3	17.8	18.4
	HI PR	246	265	280	292	276	297	314	328	314	338	357	372	358	385	407	424	403	433	458	477	445	479	506	527
	LO PR	112	119	130	139	118	126	138	147	123	131	143	152	129	138	150	160	136	144	157	168	140	149	163	173
	MBh	43.7	44.6	46.7	49.8	42.7	43.5	45.6	48.6	41.7	42.5	44.5	47.5	40.7	41.5	43.4	46.3	38.6	39.4	41.2	44.0	35.8	36.5	38.2	40.8
	S/T	0.93	0.90	0.81	0.66	0.96	0.93	0.84	0.68	0.99	0.95	0.86	0.70	1.00	0.98	0.89	0.72	1.00	1.00	0.92	0.75	1.00	1.00	0.93	0.75
	Δ T	30	29	28	24	30	30	28	24	30	30	28	24	30	30	28	24	28	29	28	24	26	27	26	23
kW	2.81	2.87	2.96	3.05	3.03	3.09	3.19	3.30	3.22	3.29	3.40	3.51	3.39	3.46	3.58	3.70	3.53	3.61	3.73	3.86	3.65	3.74	3.86	3.99	
Amps	12.4	12.6	13.0	13.4	13.2	13.5	13.9	14.3	14.2	14.5	14.9	15.4	15.1	15.4	15.8	16.4	15.9	16.3	16.7	17.3	16.7	17.1	17.6	18.2	
HI PR	244	262	277	289	274	294	311	324	311	335	354	369	354	381	403	420	399	429	453	473	441	474	501	522	
LO PR	111	118	129	137	117	125	136	145	122	130	142	151	128	136	149	158	134	143	156	166	139	148	161	172	
MBh	40.3	41.1	43.1	46.0	39.4	40.2	42.1	44.9	38.5	39.2	41.1	43.8	37.5	38.3	40.1	42.7	35.7	36.3	38.1	40.6	33.0	33.7	35.3	37.6	
S/T	0.90	0.87	0.78	0.63	0.93	0.90	0.81	0.66	0.95	0.92	0.83	0.67	0.98	0.95	0.86	0.70	1.00	0.99	0.89	0.72	1.00	0.99	0.90	0.73	
Δ T	30	30	28	24	31	30	28	25	31	30	28	25	31	30	29	25	30	30	28	24	28	28	26	23	
kW	2.74	2.80	2.89	2.98	2.95	3.02	3.11	3.21	3.14	3.21	3.31	3.42	3.30	3.37	3.49	3.60	3.44	3.52	3.63	3.76	3.56	3.64	3.76	3.89	
Amps	12.1	12.3	12.7	13.1	12.9	13.2	13.5	14.0	13.9	14.2	14.6	15.0	14.7	15.0	15.4	16.0	15.5	15.9	16.3	16.9	16.3	16.7	17.2	17.8	
HI PR	237	255	269	280	265	286	302	315	302	325	343	358	344	370	391	407	387	416	439	458	427	460	486	506	
LO PR	108	115	125	133	114	121	132	141	118	126	137	146	124	132	144	154	130	138	151	161	135	143	156	167	

IDB: Entering Indoor Dry Bulb Temperature
 High and low pressures are measured at the liquid and suction service valves.
 Shaded area reflects AHRI (TVA) conditions
 kW = Total system power
 Amps = outdoor unit amps (comp.+fan)

IDB		OUTDOOR AMBIENT TEMPERATURE																																			
		65						75						85						95						105						115					
		59	63	67	71	71	59	63	67	71	71	59	63	67	71	71	59	63	67	71	71	59	63	67	71	71	59	63	67	71	71						
70	AIRFLOW	MBh	46.2	47.9	52.5	-	45.1	46.8	51.3	-	44.1	45.7	50.0	-	43.0	44.6	48.8	-	40.8	42.3	46.4	-	37.8	39.2	43.0	-											
		S/T	0.72	0.60	0.42	-	0.75	0.62	0.43	-	0.77	0.64	0.44	-	0.79	0.66	0.46	-	0.82	0.69	0.47	-	0.83	0.69	0.48	-											
		Δ T	21	18	14	-	21	19	14	-	21	19	14	-	22	19	14	-	21	18	14	-	20	17	13	-											
	1443	kW	3.05	3.11	3.21	-	3.28	3.35	3.46	-	3.49	3.56	3.68	-	3.67	3.75	3.87	-	3.83	3.91	4.04	-	3.96	4.05	4.18	-											
		Amps	14.3	14.6	15.0	-	15.3	15.6	16.1	-	16.4	16.8	17.3	-	17.4	17.8	18.3	-	18.4	18.8	19.3	-	19.3	19.7	20.3	-											
		HI PR	239	257	271	-	268	288	304	-	305	328	346	-	347	373	394	-	390	420	443	-	431	464	490	-											
		LO PR	106	113	123	-	112	119	130	-	116	124	135	-	122	130	142	-	128	136	149	-	132	141	154	-											
		MBh	44.9	46.5	51.0	-	43.8	45.4	49.8	-	42.8	44.3	48.6	-	41.7	43.3	47.4	-	39.7	41.1	45.0	-	36.7	38.1	41.7	-											
		S/T	0.69	0.57	0.40	-	0.71	0.59	0.41	-	0.73	0.61	0.42	-	0.75	0.63	0.44	-	0.78	0.65	0.45	-	0.79	0.66	0.46	-											
		Δ T	22	19	14	-	22	19	15	-	22	19	15	-	23	19	15	-	22	19	15	-	21	18	14	-											
	kW	3.02	3.09	3.18	-	3.25	3.32	3.43	-	3.46	3.53	3.65	-	3.64	3.72	3.84	-	3.79	3.88	4.01	-	3.93	4.01	4.15	-												
	Amps	14.2	14.5	14.9	-	15.2	15.5	15.9	-	16.3	16.6	17.1	-	17.3	17.6	18.1	-	18.2	18.6	19.2	-	19.2	19.6	20.2	-												
	HI PR	236	254	269	-	265	285	301	-	302	325	343	-	343	370	390	-	386	416	439	-	427	459	485	-												
	LO PR	105	111	122	-	111	118	129	-	115	122	134	-	121	129	140	-	127	135	147	-	131	139	152	-												
	MBh	41.4	42.9	47.0	-	40.4	41.9	45.9	-	39.5	40.9	44.8	-	38.5	39.9	43.7	-	36.6	37.9	41.6	-	33.9	35.1	38.5	-												
	S/T	0.66	0.55	0.38	-	0.69	0.57	0.40	-	0.70	0.59	0.41	-	0.73	0.61	0.42	-	0.75	0.63	0.44	-	0.76	0.64	0.44	-												
	Δ T	22	19	15	-	23	20	15	-	23	20	15	-	23	20	15	-	23	19	15	-	21	18	14	-												
	kW	2.95	3.01	3.11	-	3.18	3.24	3.35	-	3.37	3.45	3.56	-	3.55	3.63	3.75	-	3.70	3.78	3.91	-	3.83	3.91	4.04	-												
	Amps	13.9	14.2	14.6	-	14.8	15.1	15.6	-	15.9	16.2	16.7	-	16.9	17.2	17.7	-	17.8	18.2	18.7	-	18.7	19.1	19.7	-												
	HI PR	229	247	260	-	257	277	292	-	293	315	332	-	333	359	379	-	375	403	426	-	414	446	471	-												
	LO PR	102	108	118	-	107	114	125	-	112	119	130	-	117	125	136	-	123	131	143	-	127	135	148	-												

IDB		OUTDOOR AMBIENT TEMPERATURE																																			
		65						75						85						95						105						115					
		59	63	67	71	71	59	63	67	71	71	59	63	67	71	71	59	63	67	71	71	59	63	67	71	71	59	63	67	71	71						
75	AIRFLOW	MBh	47.0	48.4	52.4	56.2	45.9	47.3	51.2	54.9	44.8	46.1	49.9	53.6	43.7	45.0	48.7	52.3	41.5	42.8	46.3	49.7	38.5	39.6	42.9	46.0											
		S/T	0.82	0.73	0.55	0.36	0.85	0.76	0.57	0.37	0.87	0.78	0.59	0.38	0.90	0.80	0.61	0.39	0.93	0.83	0.63	0.41	0.94	0.84	0.64	0.41											
		Δ T	25	23	19	13	25	23	19	13	25	23	19	13	25	23	19	13	25	23	19	13	23	21	17	12											
	1443	kW	3.07	3.14	3.24	3.34	3.31	3.38	3.49	3.60	3.52	3.59	3.71	3.83	3.70	3.78	3.91	4.04	3.86	3.94	4.08	4.21	3.99	4.08	4.22	4.36											
		Amps	14.5	14.7	15.1	15.6	15.4	15.7	16.2	16.7	16.6	16.9	17.4	18.0	17.5	17.9	18.4	19.0	18.5	18.9	19.5	20.1	19.5	19.9	20.5	21.2											
		HI PR	241	259	274	286	271	291	307	321	308	331	350	365	350	377	398	415	394	424	448	467	436	469	495	516											
		LO PR	107	114	124	132	113	120	131	140	117	125	136	145	123	131	143	152	129	137	150	160	134	142	155	165											
		MBh	45.6	47.0	50.8	54.6	44.6	45.9	49.7	53.3	43.5	44.8	48.5	52.0	42.4	43.7	47.3	50.8	40.3	41.5	44.9	48.2	37.4	38.5	41.6	44.7											
		S/T	0.78	0.70	0.53	0.34	0.81	0.72	0.55	0.35	0.83	0.74	0.56	0.36	0.86	0.77	0.58	0.37	0.89	0.80	0.60	0.39	0.90	0.80	0.61	0.39											
		Δ T	25	23	19	13	26	24	19	13	26	24	19	13	26	24	19	13	26	24	19	13	24	22	18	12											
	kW	3.05	3.11	3.21	3.31	3.28	3.35	3.46	3.57	3.49	3.56	3.68	3.80	3.67	3.75	3.88	4.01	3.83	3.91	4.04	4.18	3.96	4.05	4.18	4.33												
	Amps	14.3	14.6	15.0	15.5	15.3	15.6	16.1	16.6	16.4	16.8	17.3	17.8	17.4	17.8	18.3	18.9	18.4	18.8	19.3	20.0	19.3	19.7	20.3	21.0												
	HI PR	239	257	271	283	268	288	304	317	305	328	346	361	347	373	394	411	390	420	444	463	431	464	490	511												
	LO PR	106	113	123	131	112	119	130	138	116	124	135	144	122	130	142	151	128	136	149	158	132	141	154	164												
	MBh	42.1	43.4	46.9	50.4	41.1	42.4	45.8	49.2	40.2	41.3	44.8	48.0	39.2	40.3	43.7	46.9	37.2	38.3	41.5	44.5	34.5	35.5	38.4	41.2												
	S/T	0.75	0.67	0.51	0.33	0.78	0.70	0.53	0.34	0.80	0.72	0.54	0.35	0.83	0.74	0.56	0.36	0.86	0.77	0.58	0.37	0.86	0.77	0.59	0.38												
	Δ T	26	24	20	13	26	24	20	14	26	24	20	14	26	24	20	14	26	24	20	14	24	22	18	13												
	kW	2.97	3.04	3.13	3.23	3.20	3.27	3.37	3.48	3.40	3.48	3.59	3.71	3.58	3.66	3.78	3.90	3.73	3.81	3.94	4.07	3.86	3.95	4.08	4.22												
	Amps	14.0	14.3	14.7	15.1	15.0	15.3	15.7	16.2	16.0	16.4	16.8	17.4	17.0	17.3	17.8	18.4	17.9	18.3	18.8	19.5	18.8	19.3	19.8	20.5												
	HI PR	232	249	263	274	260	280	295	308	295	318	336	350	337	362	382	399	379	407	430	449	418	450	475	496												
	LO PR	103	109	119	127	108	115	126	134	113	120	131	139	118	126	138	146	124	132	144	153	128	137	149	159												

IDB: Entering Indoor Dry Bulb Temperature
 High and low pressures are measured at the liquid and suction service valves.
 Shaded area reflects ACCA (TVA) conditions
 kW = Total system power
 Amps = outdoor unit amps (comp.+fan)

IDB		OUTDOOR AMBIENT TEMPERATURE																								
		65				75				85				95				105				115				
		59	63	67	71	59	63	67	71	59	63	67	71	59	63	67	71	59	63	67	71	59	63	67	71	
80	AIRFLOW	MBh	47.8	48.9	52.2	55.8	46.7	47.7	51.0	54.5	45.6	46.6	49.8	53.2	44.5	45.5	48.6	51.9	42.3	43.2	46.1	49.3	42.3	43.2	46.1	49.3
	S/T	0.90	0.84	0.69	0.51	0.93	0.87	0.71	0.53	0.95	0.90	0.73	0.54	1.00	0.92	0.75	0.56	1.00	0.96	0.78	0.58	1.00	0.97	0.79	0.59	
	Δ T	27	26	23	18	28	27	23	18	28	27	23	18	28	27	23	18	27	26	23	18	25	25	21	17	
	kW	3.10	3.16	3.26	3.37	3.33	3.41	3.52	3.63	3.55	3.62	3.74	3.87	3.73	3.82	3.94	4.07	3.89	3.98	4.11	4.25	4.03	4.12	4.26	4.40	
	Amps	14.6	14.9	15.3	15.7	15.6	15.9	16.3	16.8	16.7	17.0	17.5	18.1	17.7	18.1	18.6	19.2	18.7	19.1	19.6	20.3	19.6	20.1	20.7	21.4	
	HI PR	244	262	277	289	273	294	311	324	311	334	353	368	354	381	402	420	398	429	453	472	440	473	500	521	
	LO PR	108	115	125	134	114	121	132	141	119	126	138	147	125	132	145	154	131	139	152	161	135	144	157	167	
	MBh	46.4	47.5	50.7	54.2	45.4	46.3	49.5	52.9	44.3	45.2	48.3	51.7	43.2	44.1	47.2	50.4	41.0	41.9	44.8	47.9	38.0	38.8	41.5	44.4	
	S/T	0.86	0.80	0.65	0.49	0.89	0.83	0.68	0.51	0.91	0.85	0.70	0.52	0.94	0.88	0.72	0.54	0.98	0.92	0.74	0.56	0.98	0.92	0.75	0.56	
	Δ T	28	27	24	19	29	28	24	19	29	28	24	19	29	28	24	19	29	27	24	19	27	26	22	18	
kW	3.07	3.14	3.24	3.34	3.31	3.38	3.49	3.60	3.52	3.59	3.71	3.83	3.70	3.78	3.91	4.04	3.86	3.94	4.08	4.21	3.99	4.08	4.22	4.36		
Amps	14.5	14.7	15.1	15.6	15.4	15.7	16.2	16.7	16.6	16.9	17.4	18.0	17.5	17.9	18.4	19.0	18.5	18.9	19.5	20.1	19.5	19.9	20.5	21.2		
HI PR	241	259	274	286	271	291	307	321	308	331	350	365	350	377	398	415	394	424	448	467	436	469	495	516		
LO PR	107	114	124	132	113	120	131	140	117	125	136	145	123	131	143	153	129	137	150	160	134	142	155	165		
MBh	42.9	43.8	46.8	50.0	41.9	42.8	45.7	48.9	40.9	41.8	44.6	47.7	39.9	40.7	43.5	46.5	37.9	38.7	41.4	44.2	35.1	35.9	38.3	40.9		
S/T	0.83	0.78	0.63	0.47	0.86	0.80	0.65	0.49	0.88	0.82	0.67	0.50	0.91	0.85	0.69	0.52	0.94	0.88	0.72	0.54	0.95	0.89	0.72	0.54		
Δ T	29	28	24	19	29	28	24	19	29	28	24	19	29	28	25	20	29	28	24	19	27	26	23	18		
kW	3.00	3.06	3.16	3.26	3.23	3.30	3.40	3.51	3.43	3.51	3.62	3.74	3.61	3.69	3.81	3.94	3.76	3.85	3.97	4.11	3.89	3.98	4.11	4.25		
Amps	14.1	14.4	14.8	15.3	15.1	15.4	15.8	16.3	16.2	16.5	17.0	17.5	17.1	17.5	18.0	18.6	18.1	18.5	19.0	19.6	19.0	19.4	20.0	20.7		
HI PR	234	252	266	277	262	282	298	311	298	321	339	354	340	366	386	403	382	412	435	453	423	455	480	501		
LO PR	104	110	120	128	110	117	127	136	114	121	132	141	120	127	139	148	125	133	146	155	130	138	151	160		
85	AIRFLOW	MBh	48.7	49.6	52.0	55.4	47.5	48.5	50.7	54.1	46.4	47.3	49.5	52.9	45.3	46.1	48.3	51.6	43.0	43.8	45.9	49.0	39.8	40.6	42.5	45.4
	S/T	0.94	0.91	0.82	0.67	0.98	0.94	0.85	0.69	1.00	0.97	0.87	0.71	1.00	1.00	0.90	0.73	1.00	1.00	0.93	0.76	1.00	1.00	0.94	0.76	
	Δ T	29	29	27	23	30	29	27	24	30	29	28	24	29	29	28	24	29	28	27	24	25	26	26	22	
	kW	3.12	3.19	3.29	3.39	3.36	3.43	3.55	3.66	3.58	3.65	3.77	3.90	3.76	3.85	3.97	4.11	3.92	4.01	4.15	4.29	4.06	4.15	4.29	4.44	
	Amps	14.7	15.0	15.4	15.9	15.7	16.0	16.4	17.0	16.8	17.2	17.7	18.2	17.8	18.2	18.7	19.3	18.8	19.2	19.8	20.5	19.8	20.2	20.8	21.5	
	HI PR	246	265	280	292	276	297	314	327	314	338	357	372	358	385	406	424	402	433	457	477	444	478	505	527	
	LO PR	109	116	127	135	115	123	134	143	120	127	139	148	126	134	146	156	132	140	153	163	136	145	158	169	
	MBh	47.2	48.2	50.4	53.8	46.2	47.0	49.3	52.6	45.1	45.9	48.1	51.3	44.0	44.8	46.9	50.1	41.8	42.6	44.6	47.6	38.7	39.4	41.3	44.1	
	S/T	0.90	0.87	0.78	0.63	0.93	0.90	0.81	0.66	0.95	0.92	0.83	0.67	0.99	0.95	0.86	0.70	1.00	0.99	0.89	0.72	1.00	1.00	0.90	0.73	
	Δ T	30	30	28	24	31	30	29	25	31	30	29	25	31	30	29	25	30	30	28	25	28	28	27	23	
kW	3.10	3.16	3.26	3.37	3.33	3.41	3.52	3.63	3.55	3.62	3.74	3.87	3.73	3.82	3.94	4.07	3.89	3.98	4.11	4.25	4.03	4.12	4.26	4.40		
Amps	14.6	14.9	15.3	15.7	15.6	15.9	16.3	16.8	16.7	17.0	17.5	18.1	17.7	18.1	18.6	19.2	18.7	19.1	19.6	20.3	19.6	20.1	20.7	21.4		
HI PR	244	262	277	289	273	294	311	324	311	334	353	368	354	381	402	420	398	429	453	472	440	473	500	521		
LO PR	108	115	125	134	114	121	132	141	119	126	138	147	125	132	145	154	131	139	152	161	135	144	157	167		
MBh	43.6	44.5	46.6	49.7	42.6	43.4	45.5	48.5	41.6	42.4	44.4	47.4	40.6	41.4	43.3	46.2	38.5	39.3	41.1	43.9	35.7	36.4	38.1	40.7		
S/T	0.87	0.84	0.75	0.61	0.90	0.87	0.78	0.63	0.92	0.89	0.80	0.65	0.95	0.92	0.83	0.67	0.99	0.95	0.86	0.70	0.99	0.96	0.87	0.70		
Δ T	31	30	29	25	31	31	29	25	31	31	29	25	31	31	29	25	31	30	29	25	29	29	28	23		
kW	3.02	3.09	3.18	3.28	3.25	3.32	3.43	3.54	3.46	3.53	3.65	3.77	3.64	3.72	3.84	3.97	3.79	3.88	4.01	4.14	3.93	4.01	4.15	4.29		
Amps	14.2	14.5	14.9	15.4	15.2	15.5	15.9	16.4	16.3	16.6	17.1	17.7	17.3	17.6	18.1	18.7	18.2	18.6	19.1	19.8	19.2	19.6	20.2	20.8		
HI PR	236	254	268	280	265	285	301	314	301	324	343	357	343	369	390	407	386	416	439	458	427	459	485	506		
LO PR	105	111	122	130	111	118	129	137	115	122	134	142	121	129	140	149	127	135	147	157	131	139	152	162		

IDB: Entering Indoor Dry Bulb Temperature
 High and low pressures are measured at the liquid and suction service valves.
 Shaded area reflects AHRI (TVA) conditions
 kW = Total system power
 Amps = outdoor unit amps (comp.+fan)

IDB		OUTDOOR AMBIENT TEMPERATURE																																				
		65						75						85						95						105						115						
		AIRFLOW			59			63			67			71			59			63			67			71			59			63			67			71
		ENTERING INDOOR WET BULB TEMPERATURE																																				
70	2221	MBh	58.1	60.2	66.0	-	56.8	58.8	64.5	-	55.4	57.4	62.9	-	54.1	56.0	61.4	-	51.4	53.2	58.3	-	47.6	49.3	54.0	-	46.2	47.9	52.4	-								
		S/T	0.78	0.65	0.45	-	0.80	0.67	0.47	-	0.83	0.69	0.48	-	0.85	0.71	0.49	-	0.88	0.74	0.51	-	0.89	0.74	0.52	-	0.85	0.71	0.49	-								
		Δ T	19	16	12	-	19	16	12	-	19	16	12	-	19	16	13	-	19	16	12	-	18	15	12	-	18	16	12	-								
		kW	3.87	3.95	4.07	-	4.15	4.24	4.36	-	4.40	4.49	4.63	-	4.62	4.71	4.86	-	4.80	4.90	5.06	-	4.96	5.07	5.23	-	4.92	5.03	5.19	-								
		Amps	18.0	18.3	18.8	-	19.1	19.5	20.0	-	20.5	20.9	21.4	-	21.6	22.0	22.6	-	22.7	23.2	23.8	-	23.9	24.4	25.0	-	23.7	24.2	24.8	-								
	1980	HI PR	194	209	221	-	218	235	248	-	248	267	282	-	283	304	321	-	318	342	361	-	351	378	399	-	348	374	395	-								
		LO PR	112	119	130	-	118	126	137	-	123	131	143	-	129	137	150	-	135	144	157	-	140	149	163	-	139	147	161	-								
		MBh	56.4	58.5	64.1	-	55.1	57.1	62.6	-	53.8	55.8	61.1	-	52.5	54.4	59.6	-	49.9	51.7	56.6	-	46.2	47.9	52.4	-	46.2	47.9	52.4	-								
		S/T	0.74	0.62	0.43	-	0.77	0.64	0.44	-	0.79	0.66	0.46	-	0.81	0.68	0.47	-	0.84	0.70	0.49	-	0.85	0.71	0.49	-	0.85	0.71	0.49	-								
		Δ T	19	17	13	-	20	17	13	-	20	17	13	-	20	17	13	-	20	17	13	-	18	16	12	-	18	16	12	-								
1752	kW	3.84	3.92	4.04	-	4.12	4.20	4.33	-	4.36	4.46	4.59	-	4.58	4.68	4.82	-	4.77	4.87	5.02	-	4.92	5.03	5.19	-	4.92	5.03	5.19	-									
	Amps	17.9	18.2	18.7	-	19.0	19.4	19.9	-	20.3	20.7	21.3	-	21.4	21.9	22.5	-	22.6	23.0	23.7	-	23.7	24.2	24.8	-	23.7	24.2	24.8	-									
	HI PR	193	207	219	-	216	232	245	-	246	264	279	-	280	301	318	-	315	339	358	-	348	374	395	-	348	374	395	-									
	LO PR	111	118	129	-	117	125	136	-	122	129	141	-	128	136	148	-	134	143	156	-	139	147	161	-	139	147	161	-									
	MBh	53.6	55.6	60.9	-	52.4	54.3	59.5	-	51.1	53.0	58.0	-	49.9	51.7	56.6	-	47.4	49.1	53.8	-	43.9	45.5	49.8	-	43.9	45.5	49.8	-									

IDB		OUTDOOR AMBIENT TEMPERATURE																																				
		65						75						85						95						105						115						
		AIRFLOW			59			63			67			71			59			63			67			71			59			63			67			71
		ENTERING INDOOR WET BULB TEMPERATURE																																				
75	2221	MBh	59.1	60.8	65.9	70.7	57.7	59.4	64.3	69.0	56.3	58.0	62.8	67.4	55.0	56.6	61.3	65.8	52.2	53.8	58.2	62.5	48.4	49.8	53.9	57.9	48.4	49.8	53.9	57.9								
		S/T	0.88	0.79	0.60	0.38	0.91	0.82	0.62	0.40	0.94	0.84	0.63	0.41	0.97	0.87	0.66	0.42	1.00	0.90	0.68	0.44	1.00	0.91	0.69	0.44	1.00	0.91	0.69	0.44								
		Δ T	22	20	16	11	22	20	16	11	22	20	17	11	22	20	17	11	22	20	16	11	22	20	19	15	11	20	19	15	11							
		kW	3.90	3.98	4.10	4.22	4.18	4.27	4.40	4.54	4.43	4.53	4.67	4.81	4.65	4.75	4.90	5.06	4.82	4.84	4.95	5.10	5.27	5.00	5.11	5.27	5.45	5.00	5.11	5.27	5.45							
		Amps	18.1	18.5	18.9	19.5	19.3	19.7	20.2	20.8	20.6	21.0	21.6	22.3	21.8	22.2	22.8	23.5	23.5	22.9	23.4	24.0	24.8	24.0	24.5	25.2	26.1	24.0	24.5	25.2	26.1							
	1980	HI PR	196	211	223	233	220	237	250	261	251	270	285	297	285	307	324	338	338	321	346	365	381	355	382	403	421	355	382	403	421							
		LO PR	113	120	131	140	119	127	139	148	124	132	144	154	130	139	151	161	161	137	145	159	169	141	150	164	175	141	150	164	175							
		MBh	57.4	59.1	63.9	68.6	56.0	57.7	62.5	67.0	54.7	56.3	61.0	65.4	53.4	55.0	59.5	63.8	63.8	50.7	52.2	56.5	60.6	47.0	48.4	52.3	56.2	47.0	48.4	52.3	56.2							
		S/T	0.84	0.75	0.57	0.37	0.87	0.78	0.59	0.38	0.89	0.80	0.61	0.39	0.92	0.83	0.63	0.40	0.92	0.96	0.86	0.65	0.42	0.97	0.86	0.65	0.42	0.97	0.86	0.65	0.42							
		Δ T	22	21	17	12	23	21	17	12	23	21	17	12	23	21	17	12	23	23	21	17	12	21	19	16	11	21	19	16	11							
1752	kW	3.87	3.95	4.07	4.19	4.15	4.24	4.37	4.50	4.40	4.49	4.63	4.78	4.62	4.72	4.86	5.02	4.86	4.80	4.91	5.06	5.22	4.96	5.07	5.23	5.40	4.96	5.07	5.23	5.40								
	Amps	18.0	18.3	18.8	19.4	19.1	19.5	20.0	20.6	20.5	20.9	21.4	22.1	21.6	22.0	22.6	23.4	23.4	22.7	23.2	23.9	24.6	23.9	24.4	25.0	25.9	23.9	24.4	25.0	25.9								
	HI PR	194	209	221	230	218	235	248	259	248	267	282	294	283	304	321	335	335	318	342	361	377	351	378	399	416	351	378	399	416								
	LO PR	112	119	130	138	118	126	137	146	123	131	143	152	129	137	150	160	160	135	144	157	167	140	149	163	173	140	149	163	173								
	MBh	54.5	56.1	60.7	65.2	53.2	54.8	59.3	63.7	52.0	53.5	57.9	62.2	50.7	52.2	56.5	60.6	60.6	48.2	49.6	53.7	57.6	44.6	45.9	49.7	53.4	44.6	45.9	49.7	53.4								

IDB: Entering Indoor Dry Bulb Temperature
 High and low pressures are measured at the liquid and suction service valves.
 Design Subcooling: 5-7 °F @ the liquid access fitting connection AHRI 95 test conditions. Design Superheat 15-18°F @ the compressor suction access fitting connection.
 Shaded area reflects ACCA (TVA) conditions
 kW = Total system power
 Amps = outdoor unit amps (comp.+fan)

IDB		OUTDOOR AMBIENT TEMPERATURE																																
		65					75					85					95					105					115							
		59	63	67	71	75	59	63	67	71	75	59	63	67	71	75	59	63	67	71	75	59	63	67	71	75	59	63	67	71	75			
ENTERING INDOOR WET BULB TEMPERATURE																																		
80	2221	MBh	60.1	61.5	65.7	70.2	58.7	60.0	64.1	68.6	57.4	58.6	62.6	66.9	56.0	57.2	61.1	65.3	53.2	54.3	58.0	62.0	49.2	50.3	53.8	57.5	53.2	54.3	58.0	62.0	49.2	50.3	53.8	57.5
		S/T	0.97	0.91	0.74	0.55	1.00	0.94	0.77	0.57	1.00	0.96	0.79	0.59	1.00	1.00	0.81	0.61	1.00	1.00	0.84	0.63	1.00	1.00	0.85	0.63	1.00	1.00	0.84	0.63	1.00	1.00	0.85	0.63
	Δ T	24	23	20	16	24	23	20	16	24	23	20	16	23	24	20	16	23	22	22	20	16	20	21	19	15	22	22	20	16	20	21	19	15
	kW	3.93	4.01	4.13	4.25	4.22	4.30	4.43	4.57	4.47	4.56	4.70	4.85	4.69	4.69	4.79	4.94	5.10	4.88	4.99	5.14	5.31	5.04	5.15	5.32	5.49	4.88	4.99	5.14	5.31	5.04	5.15	5.32	5.49
	Amps	18.3	18.6	19.1	19.6	19.4	19.8	20.3	20.9	20.8	21.2	21.8	22.4	21.9	22.4	23.0	23.7	24.2	23.1	23.6	24.2	25.0	24.2	24.7	25.4	26.3	23.1	23.6	24.2	25.0	24.2	24.7	25.4	26.3
	HI PR	198	214	225	235	223	240	253	264	253	272	288	300	288	310	328	342	342	324	349	369	385	358	386	407	425	324	349	369	385	358	386	407	425
	LO PR	114	122	133	141	121	128	140	149	125	133	146	155	132	140	153	163	163	138	147	160	171	143	152	166	177	138	147	160	171	143	152	166	177
	MBh	58.4	59.7	63.8	68.2	57.0	58.3	62.3	66.6	55.7	56.9	60.8	65.0	54.3	55.5	59.3	63.4	51.6	52.7	56.3	60.2	47.8	48.8	52.2	55.8	51.6	52.7	56.3	60.2	47.8	48.8	52.2	55.8	
	S/T	0.92	0.87	0.70	0.53	0.96	0.90	0.73	0.55	0.98	0.92	0.75	0.56	1.00	0.95	0.77	0.58	1.00	1.00	0.80	0.60	1.00	1.00	0.81	0.60	1.00	0.99	0.80	0.60	1.00	0.99	0.81	0.60	
	Δ T	25	24	21	17	25	24	21	17	25	24	21	17	25	24	21	17	25	24	24	21	17	22	23	20	16	24	24	21	17	22	23	20	16
kW	3.90	3.98	4.10	4.22	4.18	4.27	4.40	4.54	4.43	4.53	4.67	4.81	4.65	4.75	4.90	5.06	4.84	4.95	5.10	5.27	5.00	5.11	5.27	5.45	4.84	4.95	5.10	5.27	5.00	5.11	5.27	5.45		
Amps	18.1	18.5	18.9	19.5	19.3	19.7	20.2	20.8	20.6	21.0	21.6	22.3	21.8	22.2	22.8	23.5	22.9	23.4	24.0	24.8	24.1	24.5	25.2	26.1	22.9	23.4	24.0	24.8	24.1	24.5	25.2	26.1		
HI PR	196	211	223	233	220	237	250	261	251	270	285	297	286	307	324	338	321	346	365	381	355	382	403	421	321	346	365	381	355	382	403	421		
LO PR	113	120	131	140	119	127	139	148	124	132	144	154	130	139	152	161	137	145	159	169	141	150	164	175	137	145	159	169	141	150	164	175		
MBh	55.5	56.7	60.6	64.7	54.2	55.4	59.2	63.2	52.9	54.1	57.7	61.7	51.6	52.7	56.3	60.2	49.0	50.1	53.5	57.2	45.4	46.4	49.6	53.0	49.0	50.1	53.5	57.2	45.4	46.4	49.6	53.0		
S/T	0.88	0.83	0.68	0.50	0.92	0.86	0.70	0.52	0.94	0.88	0.72	0.54	0.97	0.91	0.74	0.55	1.01	0.94	0.77	0.57	1.02	0.95	0.78	0.58	1.01	0.94	0.77	0.57	1.02	0.95	0.78	0.58		
Δ T	26	25	21	17	26	25	22	17	26	25	22	17	26	25	22	17	26	25	25	22	17	24	23	20	16	26	25	22	17	24	23	20	16	
kW	3.84	3.92	4.04	4.16	4.12	4.20	4.33	4.47	4.36	4.46	4.59	4.74	4.58	4.68	4.82	4.98	4.77	4.87	5.02	5.18	4.92	5.03	5.19	5.36	4.77	4.87	5.02	5.18	4.92	5.03	5.19	5.36		
Amps	17.9	18.2	18.7	19.2	19.0	19.4	19.9	20.5	20.3	20.7	21.3	21.9	21.4	21.9	22.5	23.2	22.6	23.0	23.7	24.4	23.7	24.2	24.8	25.6	22.6	23.0	23.7	24.4	23.7	24.2	24.8	25.6		
HI PR	193	207	219	228	216	232	245	256	246	264	279	291	280	301	318	332	315	339	358	373	348	374	395	412	315	339	358	373	348	374	395	412		
LO PR	111	118	129	137	117	125	136	145	122	129	141	151	128	136	148	158	134	143	156	166	139	147	161	171	134	143	156	166	139	147	161	171		
85	2221	MBh	61.2	62.4	65.3	69.7	59.8	60.9	63.8	68.1	58.4	59.5	62.3	66.5	56.9	58.0	60.8	64.8	54.1	55.1	57.7	61.6	50.1	51.1	53.5	57.1	54.1	55.1	57.7	61.6	50.1	51.1	53.5	57.1
		S/T	1.00	0.98	0.88	0.72	1.00	1.00	0.92	0.74	1.00	1.00	0.94	0.76	1.00	1.00	0.97	0.79	1.00	1.00	0.96	0.78	1.00	1.00	0.82	0.82	1.00	1.00	0.96	0.78	1.00	1.00	0.82	0.82
	Δ T	25	25	24	21	25	25	24	21	24	25	24	21	24	24	24	21	24	22	23	24	21	21	21	22	19	22	23	24	21	21	21	22	19
	kW	3.96	4.04	4.16	4.29	4.25	4.34	4.47	4.61	4.50	4.60	4.74	4.89	4.73	4.83	4.98	5.14	4.92	5.03	5.19	5.35	5.09	5.19	5.36	5.54	4.92	5.03	5.19	5.35	5.09	5.19	5.36	5.54	
	Amps	18.4	18.7	19.2	19.8	19.6	19.9	20.5	21.1	20.9	21.3	21.9	22.6	22.1	22.5	23.2	23.9	23.3	23.7	24.4	25.2	24.4	24.9	25.6	26.5	23.3	23.7	24.4	25.2	24.4	24.9	25.6	26.5	
	HI PR	200	216	228	237	225	242	256	266	256	275	291	303	291	313	331	345	328	353	372	388	362	390	411	429	328	353	372	388	362	390	411	429	
	LO PR	115	123	134	143	122	130	142	151	127	135	147	157	133	142	155	165	139	148	162	172	144	153	168	178	139	148	162	172	144	153	168	178	
	MBh	59.4	60.6	63.4	67.7	58.0	59.2	62.0	66.1	56.7	57.7	60.5	64.5	55.3	56.3	59.0	63.0	52.5	53.5	56.1	59.8	48.6	49.6	51.9	55.4	52.5	53.5	56.1	59.8	48.6	49.6	51.9	55.4	
	S/T	0.97	0.93	0.84	0.68	1.00	0.97	0.87	0.71	1.00	0.99	0.90	0.73	1.00	1.00	0.92	0.75	1.00	1.00	0.96	0.78	1.00	1.00	0.97	0.79	1.00	1.00	0.96	0.78	1.00	1.00	0.97	0.79	
	Δ T	27	26	25	21	27	27	25	22	26	27	25	22	26	26	25	22	26	24	25	25	22	23	23	20	20	24	25	25	22	23	23	23	20
kW	3.93	4.01	4.13	4.25	4.22	4.30	4.43	4.57	4.47	4.56	4.70	4.85	4.69	4.79	4.94	5.10	4.88	4.99	5.14	5.31	5.04	5.15	5.32	5.49	4.88	4.99	5.14	5.31	5.04	5.15	5.32	5.49		
Amps	18.3	18.6	19.1	19.6	19.4	19.8	20.3	20.9	20.8	21.2	21.8	22.4	21.9	22.4	23.0	23.7	23.1	23.6	24.2	25.0	24.2	24.7	25.4	26.3	23.1	23.6	24.2	25.0	24.2	24.7	25.4	26.3		
HI PR	198	214	225	235	223	240	253	264	253	272	288	300	288	310	328	342	324	349	369	385	358	386	407	425	324	349	369	385	358	386	407	425		
LO PR	114	122	133	141	121	128	140	149	125	133	146	155	132	140	153	163	138	147	160	171	143	152	166	177	138	147	160	171	143	152	166	177		
MBh	56.4	57.5	60.3	64.3	55.1	56.2	58.9	62.8	53.8	54.9	57.5	61.3	52.5	53.5	56.1	59.8	49.9	50.8	53.3	56.8	46.2	47.1	49.3	52.6	49.9	50.8	53.3	56.8	46.2	47.1	49.3	52.6		
S/T	0.93	0.89	0.81	0.66	0.96	0.93	0.84	0.68	0.99	0.95	0.86	0.70	1.00	0.98	0.89	0.72	1.00	1.00	0.92	0.75	1.00	1.00	0.93	0.75	1.00	1.00	0.92	0.75	1.00	1.00	0.93	0.75		
Δ T	27	27	26	22	28	27	26	22	28	27	26	22	28	28	26	23	26	27	27	26	22	24	25	24	21	26	27	26	22	24	25	24	21	
kW	3.87	3.95	4.07	4.19	4.15	4.24	4.36	4.50	4.40	4.49	4.63	4.77	4.62	4.71	4.86	5.02	4.80	4.90	5.06	5.22	4.96	5.07	5.23	5.40	4.80	4.90	5.06	5.22	4.96	5.07	5.23	5.40		
Amps	18.0	18.3	18.8	19.4	19.1	19.5	20.0	20.6	20.5	20.9	21.4	22.1	21.6	22.0	22.6	23.3	22.7	23.2	23.8	24.6	23.9	24.4	25.0	25.9	22.7	23.2	23.8	24.6	23.9	24.4	25.0	25.9		
HI PR	194	209	221	230	218	235	248	259	248	267	282	294	283	304	321	335	318	342	361	377	351	378	399	416	318	342	361	377	351	378	399	416		
LO PR	112	119	13																															

APG1624060M41** - RISE RANGE: 35° - 65°

TAP	LOW COOL	HIGH COOL	LOW HEAT		HIGH HEAT	
			CFM	RISE	CFM	RISE
A-	505	675	540	63	720	63
A	565	750	600	56	800	56
A+	620	825	660	51	880	51
B-	540	720	610	55	810	56
B	600	800	675	50	900	50
B+	660	880	745	45	990	45
C-	560	745	660	51	880	51
C	620	825	735	46	980	46
C+	685	910	810	42	1075	42
D-	575	765	720	47	960	47
D	640	850	800	42	1065	42
D+	700	935	880	38	1170	38

APG1630080M41** - RISE RANGE: 35° - 65°

TAP	LOW COOL	HIGH COOL	LOW HEAT		HIGH HEAT	
			CFM	RISE	CFM	RISE
A-	545	810	720	63	960	63
A	605	900	800	56	1065	56
A+	665	990	880	51	1170	51
B-	605	900	810	56	1075	56
B	670	1000	900	50	1195	50
B+	735	1100	990	45	1315	46
C-	650	970	900	50	1195	50
C	720	1075	1000	45	1330	45
C+	795	1185	1100	41	1465	41
D-	665	990	990	45	1315	46
D	735	1100	1100	41	1465	41
D+	810	1210	1210	37	1610	37

APG1636080M41** - RISE RANGE: 35° - 65°

TAP	LOW COOL	HIGH COOL	LOW HEAT		HIGH HEAT	
			CFM	RISE	CFM	RISE
A-	680	1015	720	63	960	63
A	755	1125	800	56	1065	56
A+	830	1240	880	51	1170	51
B-	725	1080	810	56	1075	56
B	805	1200	900	50	1195	50
B+	885	1320	990	45	1315	46
C-	755	1125	900	50	1195	50
C	840	1250	1000	45	1330	45
C+	920	1375	1100	41	1465	41
D-	800	1195	990	45	1315	46
D	890	1325	1100	41	1465	41
D+	980	1460	1210	37	1610	37

APG1642100M41** - RISE RANGE: 35° - 65°

TAP	LOW COOL	HIGH COOL	LOW HEAT		HIGH HEAT	
			CFM	RISE	CFM	RISE
A-	970	1170	915	61	1215	62
A	1080	1300	1015	55	1350	56
A+	1185	1430	1115	50	1485	51
B-	1045	1260	1015	55	1350	56
B	1160	1400	1125	50	1495	50
B+	1280	1540	1240	45	1650	45
C-	1085	1305	1125	50	1495	50
C	1205	1450	1250	45	1665	45
C+	1325	1595	1375	41	1830	41
D-	1120	1350	1240	45	1650	45
D	1245	1500	1375	41	1830	41
D+	1370	1650	1515	37	2015	37

APG1648100M41** - RISE RANGE: 35° - 65°

TAP	LOW COOL	HIGH COOL	LOW HEAT		HIGH HEAT	
			CFM	RISE	CFM	RISE
A-	1150	1305	900	63	1195	63
A	1275	1450	1000	56	1330	56
A+	1405	1595	1100	51	1465	51
B-	1190	1350	1015	55	1350	56
B	1320	1500	1125	50	1495	50
B+	1450	1650	1240	45	1650	45
C-	1230	1395	1125	50	1495	50
C	1365	1550	1250	45	1665	45
C+	1500	1705	1375	41	1830	41
D-	1265	1440	1240	45	1650	45
D	1410	1600	1375	41	1830	41
D+	1550	1760	1515	37	2015	37

APG1660140M41** - RISE RANGE: 35° - 65°

TAP	LOW COOL	HIGH COOL	LOW HEAT		HIGH HEAT	
			CFM	RISE	CFM	RISE
A-	1250	1800	1250	59	1800	58
A	1390	2000	1390	53	2000	53
A+	1530	2200	1530	48	2200	48
B-	1155	1665	1155	64	1665	63
B	1285	1850	1285	57	1850	57
B+	1415	2035	1415	52	2035	52
C-	1000	1440	1000	X	1440	X
C	1110	1600	1110	X	1600	X
C+	1225	1760	1220	60	1760	60
D-	845	1215	845	X	1215	X
D	940	1350	940	X	1350	X
D+	1030	1485	1035	X	1485	X

X = Outside of Temperature Rise Range - Not Recommended.

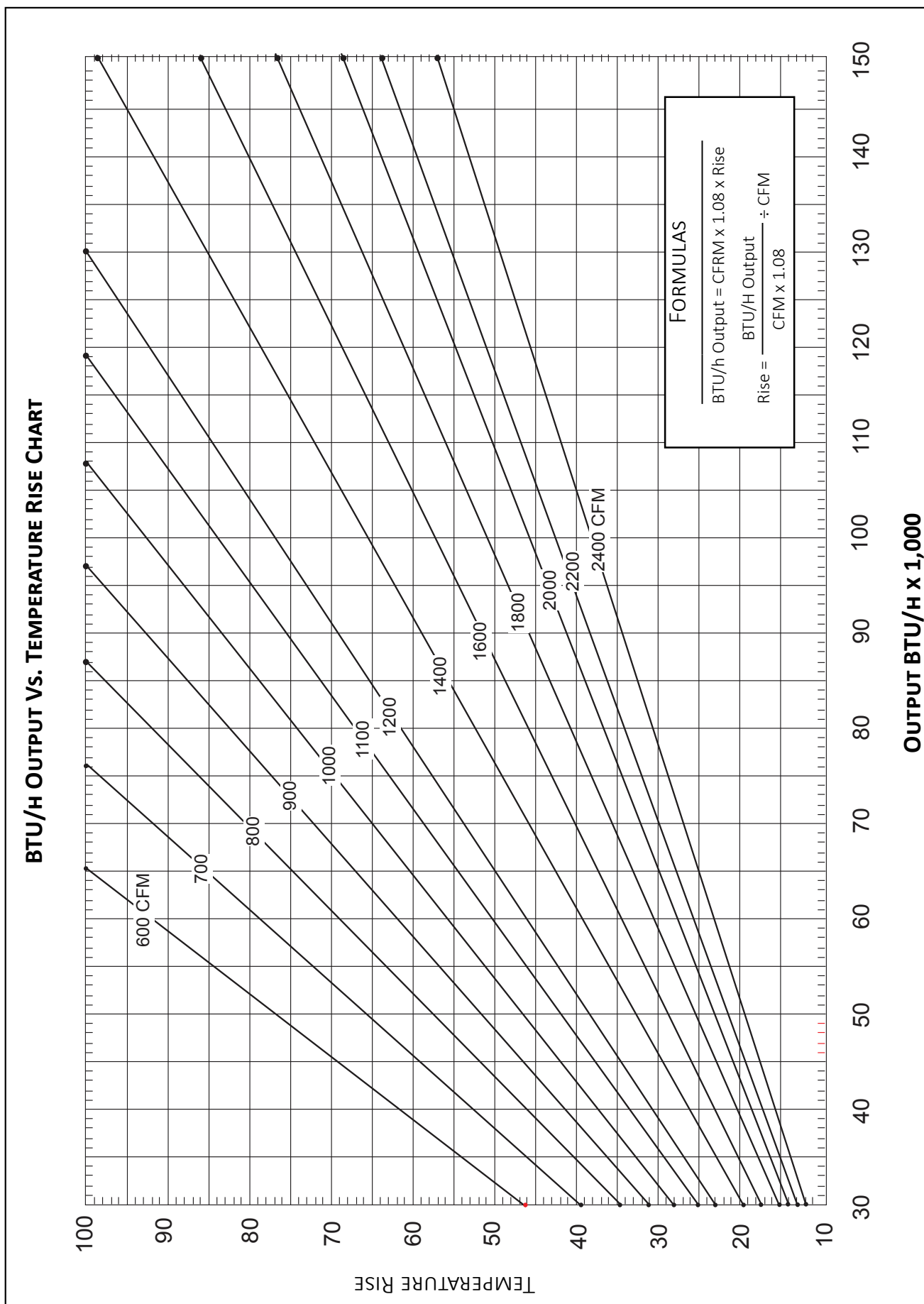

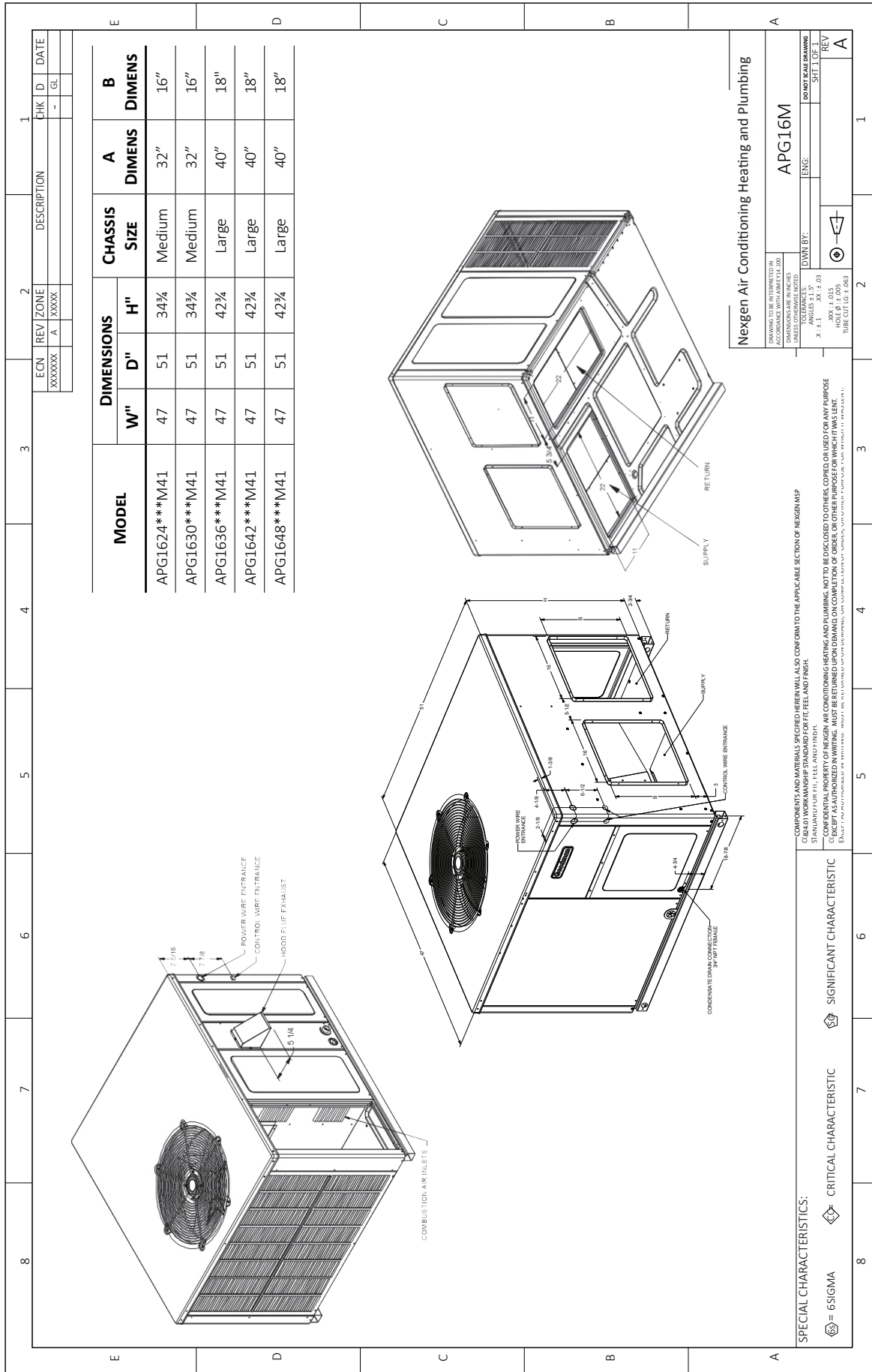

Nexgen Air Conditioning Heating and Plumbing

DRAWING TO BE INTERPRETED IN ACCORDANCE WITH ASHRAE 90.1 UNLESS OTHERWISE NOTED	
APG16M	APG16M
DATE: 08.14.03	REV: A
BY: J. J. O'NEILL	CHK: J. J. O'NEILL
DESIGNED BY: J. J. O'NEILL	ENGINEER: J. J. O'NEILL
DO NOT SCALE DRAWING	

COMPONENTS AND MATERIALS SPECIFIED HEREIN WILL ALSO CONFORM TO THE APPLICABLE SECTION OF NEXGEN/ASP GIB2401 WORKMANSHIP STANDARD FOR FIT, FEEL AND FINISH.
 THIS DRAWING IS FOR INFORMATION ONLY. IT IS NOT TO BE USED FOR ANY PURPOSE EXCEPT AS AUTHORIZED IN WRITING. MUST BE RETURNED UNLESS OTHERWISE SPECIFIED.
 EXACT FIT AND FINISH SHALL BE THE RESPONSIBILITY OF THE INSTALLER.

SPECIAL CHARACTERISTICS:
 65 = 6SIGMA
 CRITICAL CHARACTERISTIC
 SIGNIFICANT CHARACTERISTIC

MODEL	A DIMENS	B DIMENS	C DIMENS
APG1660***M41	42.840	20.555	30.055

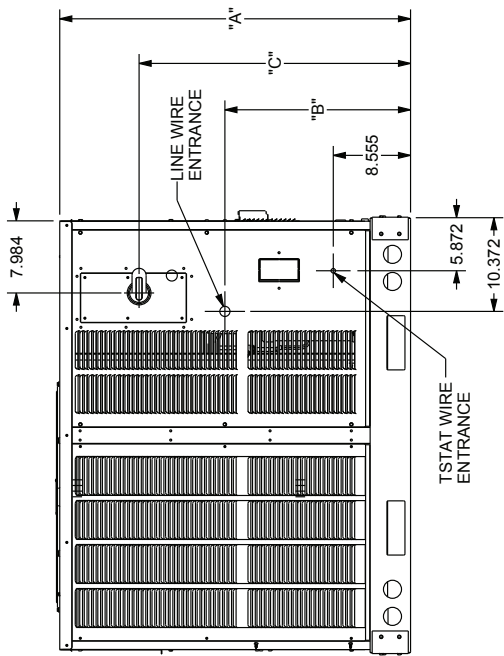
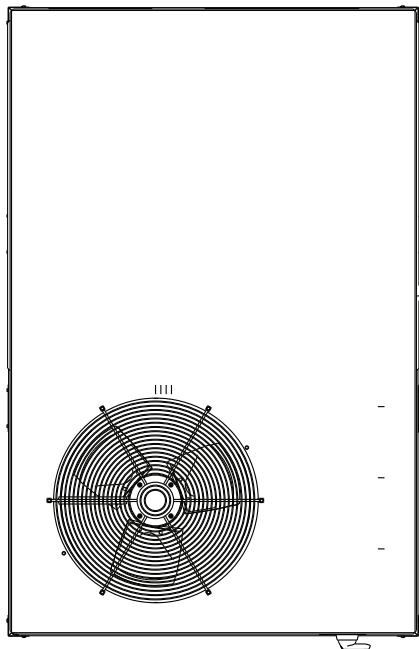

TOP VIEW

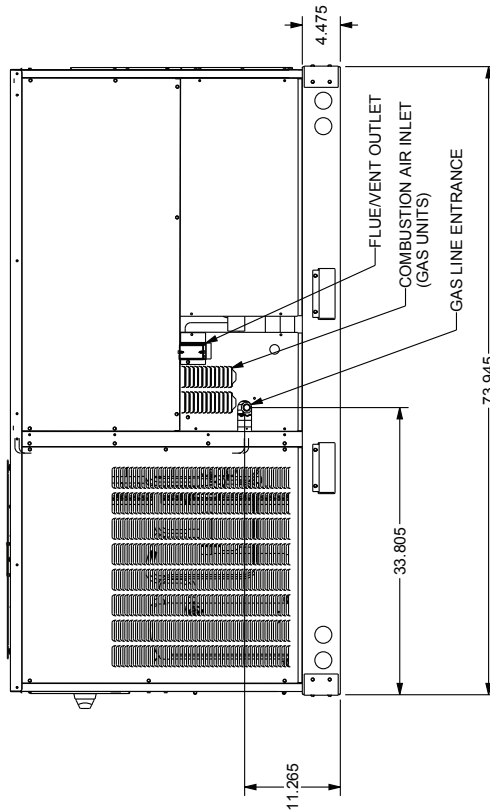

FRONT VIEW

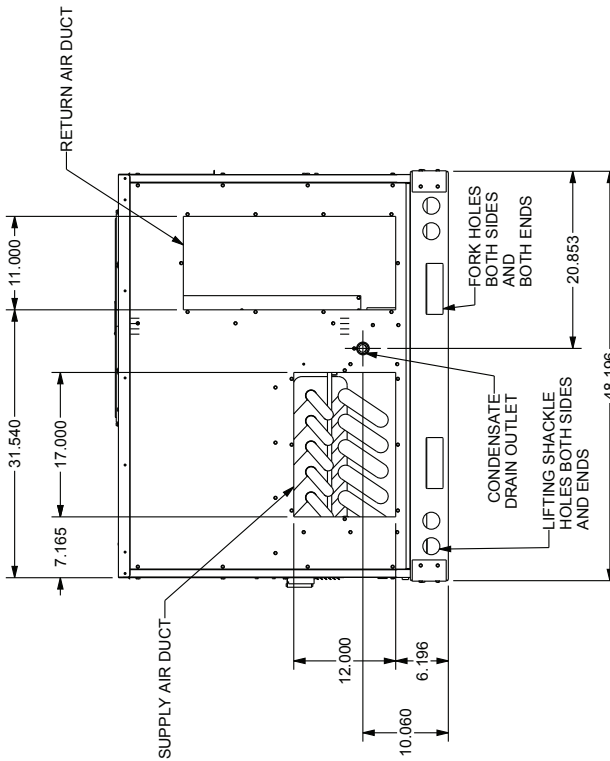

RIGHT END VIEW

ALL DIMENSIONS GIVEN ARE IN INCHES
ALL DIMENSIONS AND SPECIFICATIONS ARE SUBJECT TO CHANGE WITHOUT NOTICE

Provisions for forks have been included in the unit base frame. No other fork locations are approved.

- Unit must be lifted by the four lifting holes located at the base frame corners.
- Lifting cables should be attached to the unit with shackles.
- The distance between the crane hook and the top of the unit must not be less than 60”.
- Two spreader bars must span over the unit to prevent damage to the cabinet by the lift cables. Spreader bars must be of sufficient length so that cables do not come in contact with the unit during transport. Remove wood struts mounted beneath unit base frame before setting unit on roof curb. These struts are intended to protect unit base frame from fork lift damage. To remove the struts, extract the sheet metal retainers and pull the struts through the base of the unit. Refer to rigging label on the unit.

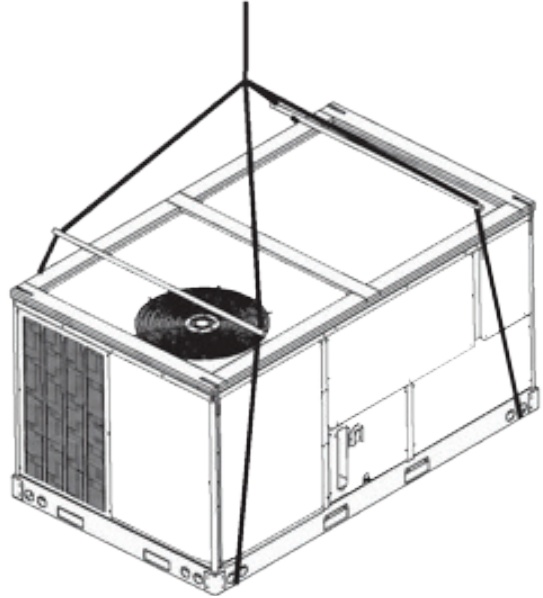

Important: If using bottom discharge with roof curb, duct-work should be attached to the curb prior to installing the unit. Duct-work dimensions are shown in Roof Curb Installation Instructions Manual.

Refer to the Roof Curb Installation Instructions for proper curb installation. Curbing must be installed in compliance with the National Roofing Contractors Association Manual.

Lower unit carefully onto roof mounting curb. While rigging the unit, the center of gravity will cause the condenser end to be lower than the supply air end.

Bring condenser end of unit into alignment with the curb. With condenser end of the unit resting on curb member and using curb as a fulcrum, lower opposite end of the unit until entire unit is seated on the curb. When a rectangular cantilever curb is used, take care to center the unit. Check for proper alignment and orientation of supply and return openings with duct.

To assist in determining rigging requirements, unit weights are shown below.

Curb installations must comply with local codes and should follow the established guidelines of the National Roofing Contractors Association.

Proper unit installation requires that the roof curb be firmly and permanently attached to the roof structure. Check for adequate fastening method prior to setting the unit on the curb.

Full perimeter roof curbs are available from the factory and are shipped unassembled. The installing contractor is responsible for field assembly, squaring, leveling, and mounting on the roof structure. All required hardware necessary for the assembly of the sheet metal curb is included in the curb accessory package.

- Determine sufficient structural support before locating and mounting the curb and package unit.
- Duct-work must be constructed using industry guidelines. The duct-work must be placed into the roof curb before mounting the package unit. Our full perimeter curbs include duct connection frames to be assembled with the curb. Cantilevered-type curbs are not available from the factory.
- Contractor furnishes curb insulation, cant strips, flashing, and general roofing material.
- Support curbs on parallel sides with roof members. To prevent damage to the unit, the roof members cannot penetrate supply and return duct openings.

Note: The unit and curb accessories are designed to allow vertical duct installation before unit placement. Duct installation after unit placement is not recommended.

See the manual shipped with the roof curb for assembly and installation instructions.

CORNER & CENTER-OF-GRAVITY LOCATIONS

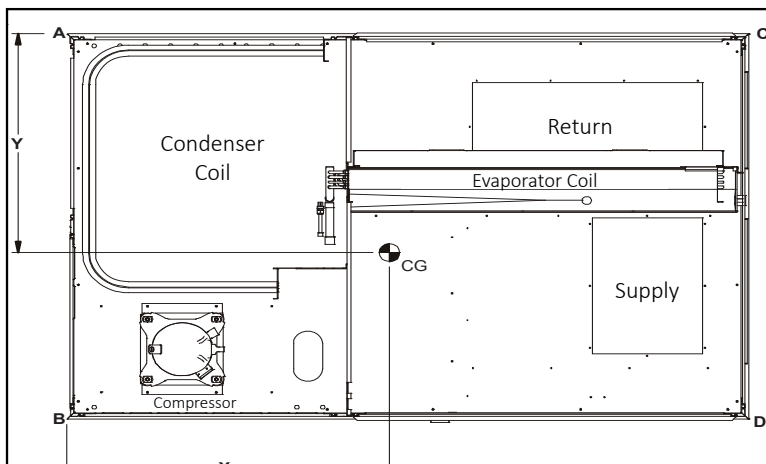

MODEL	X (In)	Y (In)	SHIPPING WEIGHT (LBS)	OPERATING WEIGHT (LBS)
APG1660***M41	46.4	28.1	655	629

MODEL	CORNER WEIGHTS (LBS.)			
	A	B	C	D
APG1660***M41	186	204	65	174

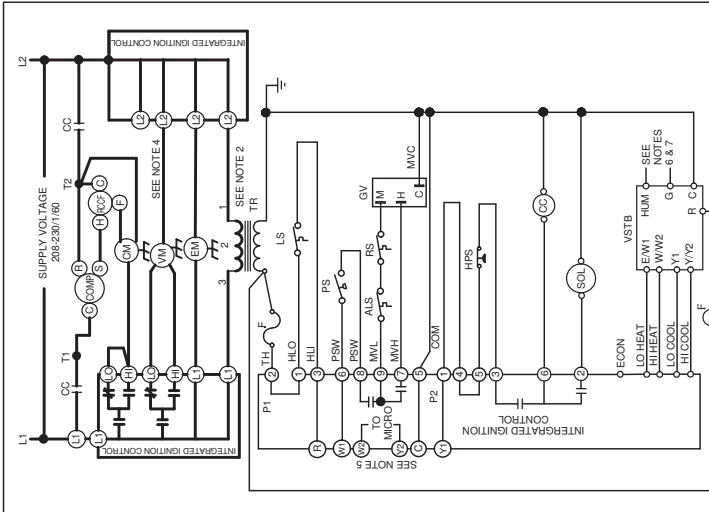

DIAGNOSTIC LED	FLASHES	STATUS	CHECK
	ON	NORMAL OPERATION	CHECK INPUT POWER
	OFF	NO POWER OR INTERNAL FAULT	REPLACE CONTROL
	1 FLASH	IGNITION FAILURE	GAS FLOW GAS VALVE FLAME SENSOR CHECK ROLL OUT LIMIT SW
	2 FLASHES	PRESSURE SWITCH OPEN	CHECK PRESSURE SWITCH
	3 FLASHES	PRESSURE SWITCH CLOSED WITHOUT INDUCER ON	CHECK PRESSURE SWITCH
	4 FLASHES	OPEN LIMIT SWITCH	CHECK MAIN LIMIT SWITCH
	5 FLASHES	FALSE FLAME DETECTED	CHECK GAS VALVE CHECK FOR SHORTS IN FLAME SENSOR WIRING
	6 FLASHES	COMPR. SHORT CYCLE DELAY	3 MIN.COMPR. SHORT CYCLE DELAY
	7 FLASHES	LIMIT OPEN 5 TIMES IN SAME CALL FOR HEAT	CHECK MAIN LIMIT SWITCH
	8 FLASHES	IDT/ODT OPEN	CHECK MAIN LIMIT SWITCH AND 4 ON 5 CIRCUIT CONNECTOR
	9 FLASHES	PS/WLOC OPEN	CHECK REFRIGRANT CHARGE OR HEAD PRESSURE
AMBER	OFF	NO FLAME PRESENT	GAS FLOW
	ON	NORMAL FLAME PRESENT	GAS PRESSURE
	1 FLASH	LOW FLAME SIGNAL	FLAME SENSOR
	2 FLASHES	FALSE FLAME DETECTED	CHECK FOR SHORTS IN FLAME SENSOR WIRING

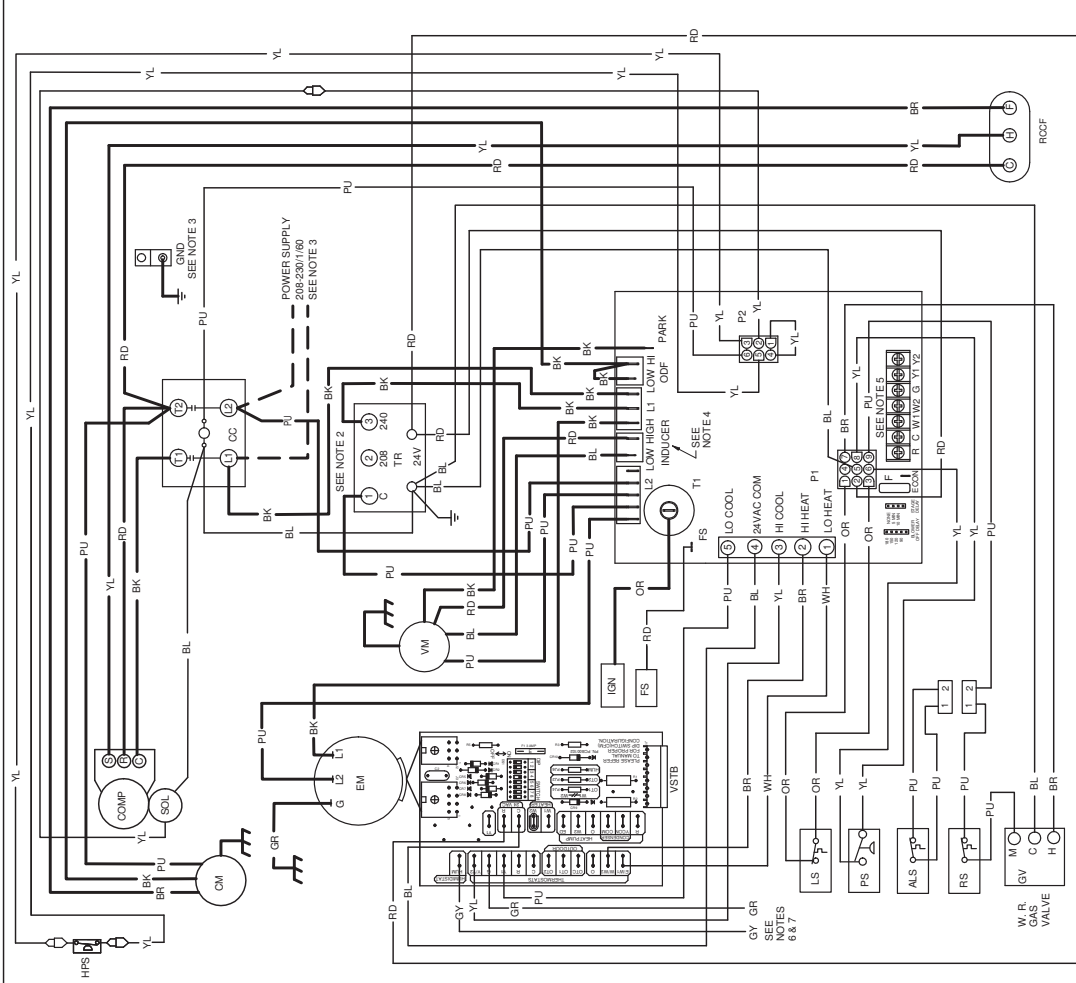

NOTES

- REPLACEMENT WIRE MUST BE THE SAME SIZE AND TYPE OF INSULATION AS ORIGINAL (USE COPPER CONDUCTOR ONLY).
- FROM TERMINAL 3 TO TERMINAL 2 ON TRANSFORMER.
- USE COPPER CONDUCTORS ONLY.
- FOR 208V OPERATION REMOVE BLUE LEAD FROM INDUCER LOW INDUCER LOW TERMINAL. PLACE BLUE LEAD ON PARK TERMINAL.
- USE NEC CLASS 2 WIRE FOR THERMOSTAT FIELD WIRING.
- FROM ROOM THERMOSTAT TO GREEN WIRE FROM VSTB. SEE INSTALLATION INSTRUCTIONS FOR DETAILS.
- FOR DEHUMIDIFICATION, CONNECT A 3WVAC DEHUMIDISTAT THAT R ON I/C; SEE INSTALLATION INSTRUCTIONS FOR DETAILS. CUT "HUM" JUMPER ON VSTB.

FACTORY WIRING

- LINE VOLTAGE
- OPTIONAL HIGH VOLTAGE
- FIELD WIRING
- HIGH VOLTAGE
- LOW VOLTAGE

WIRE CODE

- BK BLACK
- BL BLUE
- BR BROWN
- GR GREEN
- GY GRAY
- OR ORANGE
- PK PINK
- PU PURPLE
- WH WHITE
- YL YELLOW

COMPONENT LEGEND

- ALS AUXILIARY LIMIT SWITCH
- CM COMPRESSOR MOTOR
- COMP COMPRESSOR
- EM ELECTRIC MOTOR
- FM FAN MOTOR
- FS FLAME SENSOR
- GND EQUIPMENT GROUND
- HPS HIGH PRESSURE SWITCH
- IC INTEGRATED IGNITION CONTROL
- LS LIMIT SWITCH
- ODF OUTDOOR FAN
- PS PRESSURE SWITCH
- RCGF RUN CAPACITOR FOR COMPRESSOR/FAN
- RS ROLL OUT SWITCH
- SOL SOLENOID (2ND STAGE COOL)
- TR TRANSFORMER
- VSTB VARIABLE SPEED TERMINAL BOARD

TRANSFORMER HIGH

- TH HI LIMIT OUTPUT
- HLO HI LIMIT INPUT
- MV MAIN GAS VALVE HIGH
- MWL MAIN GAS VALVE LOW
- MWC MAIN GAS VALVE COMMON

WIRE CODE

- W,R GAS VALVE
- C C
- H H
- B B
- R R

NOTES

- REPLACEMENT WIRE MUST BE THE SAME SIZE AND TYPE OF INSULATION AS ORIGINAL (USE COPPER CONDUCTOR ONLY).
- FROM TERMINAL 3 TO TERMINAL 2 ON TRANSFORMER.
- USE COPPER CONDUCTORS ONLY.
- FOR 208V OPERATION REMOVE BLUE LEAD FROM INDUCER LOW INDUCER LOW TERMINAL. PLACE BLUE LEAD ON PARK TERMINAL.
- USE NEC CLASS 2 WIRE FOR THERMOSTAT FIELD WIRING.
- FROM ROOM THERMOSTAT TO GREEN WIRE FROM VSTB. SEE INSTALLATION INSTRUCTIONS FOR DETAILS.
- FOR DEHUMIDIFICATION, CONNECT A 3WVAC DEHUMIDISTAT THAT R ON I/C; SEE INSTALLATION INSTRUCTIONS FOR DETAILS. CUT "HUM" JUMPER ON VSTB.

0140G0454A



Wiring is subject to change. Always refer to the wiring diagram or the unit for the most up-to-date wiring.

WARNING

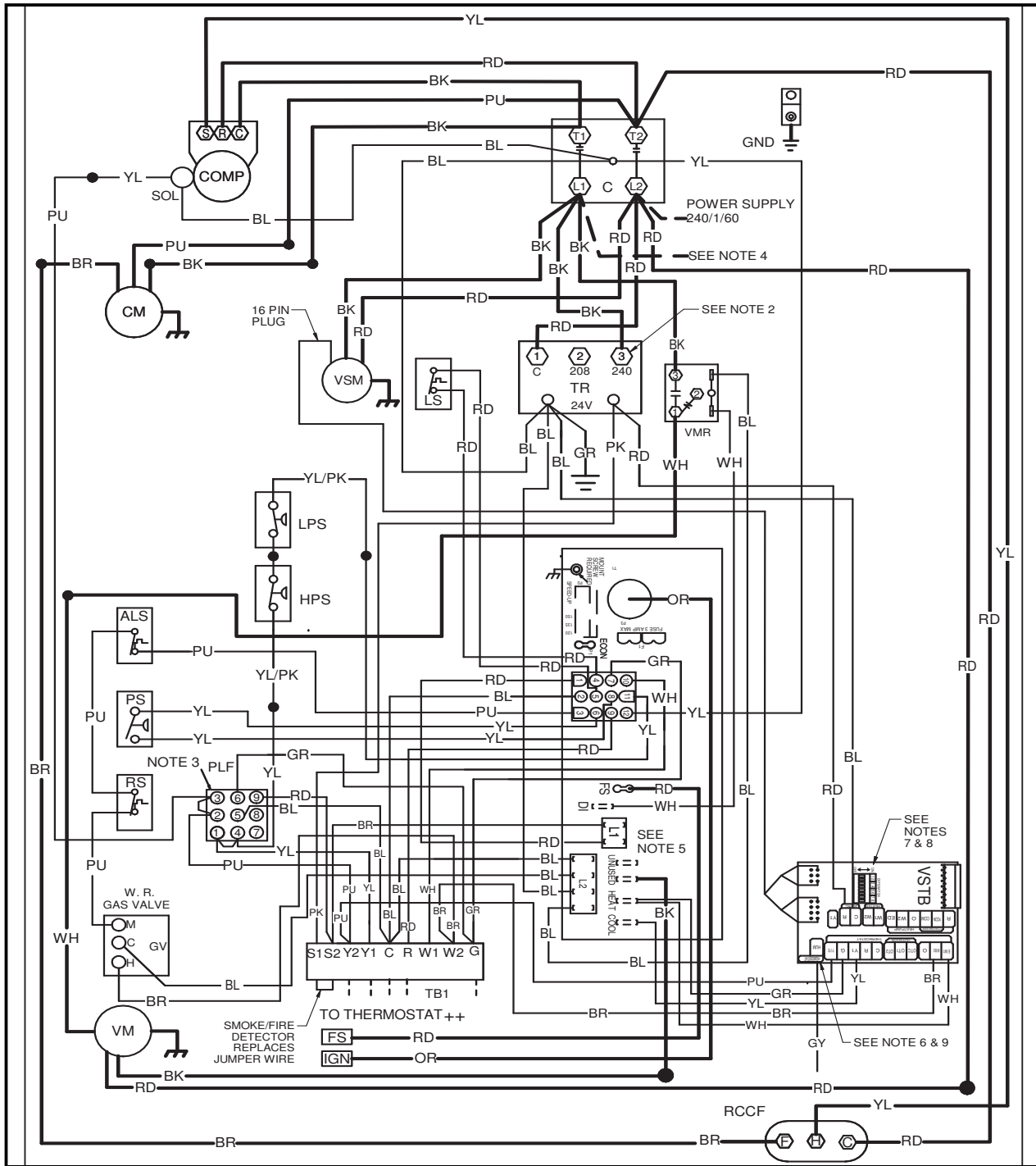
High Voltage: Disconnect all power before servicing or installing this unit. Multiple power sources may be present. Failure to do so may cause property damage, personal injury, or death.



Wiring is subject to change. Always refer to the wiring diagram or the unit for the most up-to-date wiring.

	<p>WARNING</p>	<p>High Voltage: Disconnect all power before servicing or installing this unit. Multiple power sources may be present. Failure to do so may cause property damage, personal injury, or death.</p>	
---	-----------------------	--	---

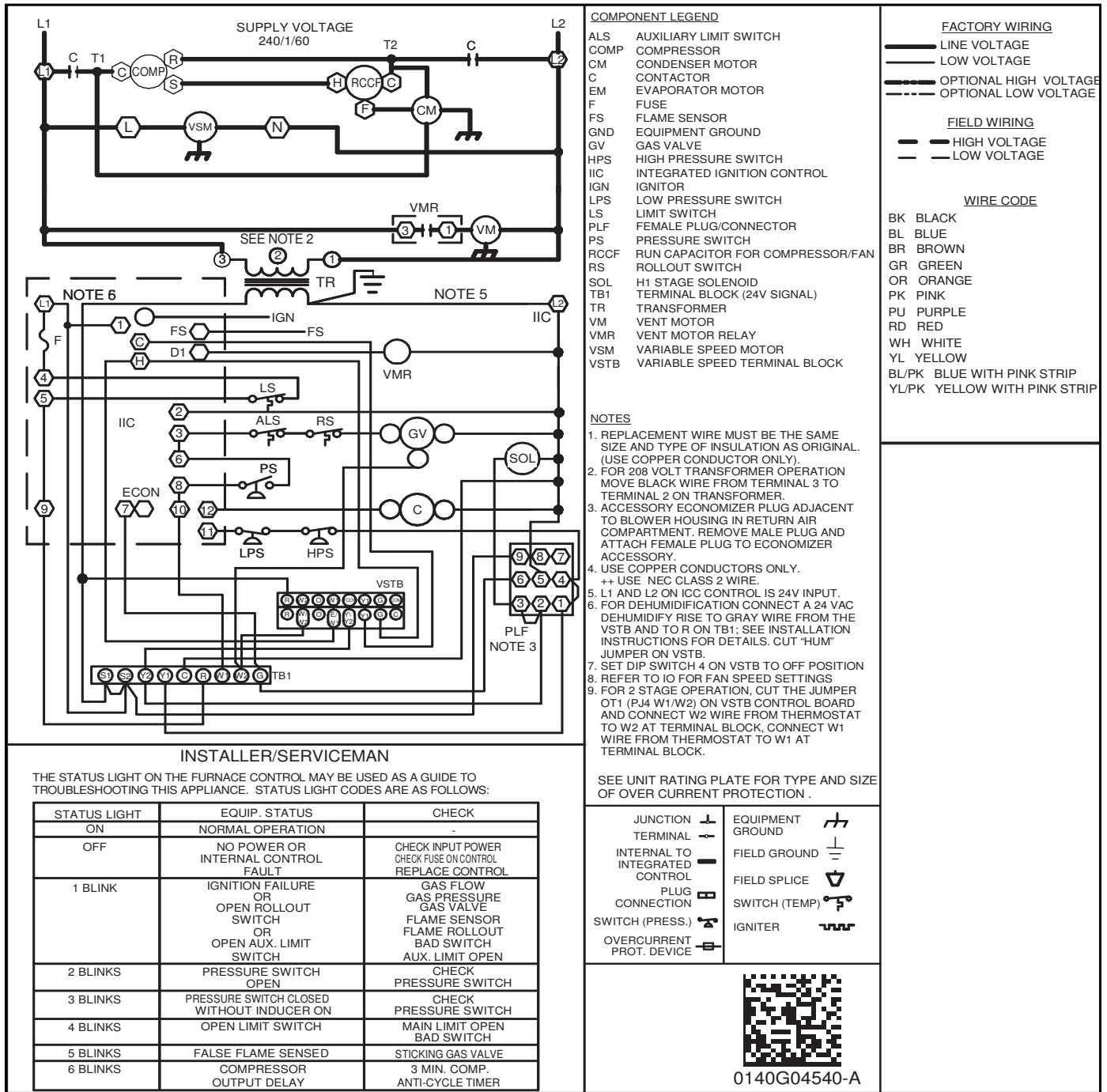

Wiring is subject to change. Always refer to the wiring diagram or the unit for the most up-to-date wiring.



High Voltage: Disconnect all power before servicing or installing this unit. Multiple power sources may be present. Failure to do so may cause property damage, personal injury, or death.



FOR THE APG1624-48*M41** UNITS**

ACCESSORY DESCRIPTION	ITEM NUMBER	
	MEDIUM CHASSIS	LARGE CHASSIS
Concentric Kit	CDK36	CDK4872
Downflow Economizer	PGEDJ101/102	PGEDJ103
Downflow Internal Filter Rack (with economizer)	DDNIFRPGMM	N/A (built into economizer)
Downflow Internal Filter Rack (no economizer)	PGFR102	PGFR103
Downflow Manual Damper	PGMDD101/102	PGMDD103
Downflow Motorized Damper	PGMDMD101/102	PGMDMD103
Downflow Square to Round	SQRPG101/102	SQRPG103
Economizer Wiring Harness (2-4 Tons)	0259L00412	0259L00412
External Horizontal Filter Rack	DPHFRA	DPHFRA
Flue Extension Kit	FLHDKT-1	FLHDKT-1
High-Altitude Kit	HA-03	HA-03
Horizontal Duct Cover	20464501PDGK	20464502PDGK
Horizontal Economizer	DHZECNJPGCHM	DHZECNJPGCHL
Horizontal Manual Damper	PGMDH102	PGMDH103
Horizontal Motorized Damper	PGMDMH102	PGMDMH103
Horizontal Square to Round	SQRPGH101/102	SQRPGH103
Internal Horizontal Filter Rack	DHZIFRPGCHA	DHZIFRPGCHA
LP Conversion Kit	LPM-08	LPM-08
Outdoor Thermostat with Housing	OTDFPKG-01	OTDFPKG-01
Roof Curb	D14CRBPGCHMA	D14CRBPGCHMA

FOR THE APG1660*M41** UNITS**

ITEM #	DESCRIPTION
14CURB3672	14" Roof Curb
D25FD3672	25% Manual Fresh Air Damper
D25MFD3672	25% Motorized Fresh Air Damper
CDK4872	Concentric Duct Kit
DDNECNJ3672B	Low-leak Downflow Economizer
DDNECNJ3672NR	Downflow Economizer w/o Barometric Relief
DDNSQRD487218	Downflow Square-to-Round Adapter (18" Round)
DHZECNJ3672	Horizontal Economizer
FSK01A	Freeze Stat Kit
GHRC-1	Hurricane Restraint Clips
HA-02	High Altitude Kit
GHRC-1	Hurricane Restraint Clips
DBRD3672	Barometric Relief Damper
LAKT01	Low-Ambient Kit
LPM-06	LP Conversion Kit
220-GX-01	Flue Extension Kit