



## APH14M

**Packaged Heat Pump**  
**2 to 5 Tons**  
**12 SEER / 8.0 HSPF**

Cooling Capacity: 24,000 – 58,000 BTU/h  
Heating Capacity: 23,000 – 57,500 BTU/h

Nomenclature .....	2
Product Specifications .....	3
Expanded Cooling Data .....	4
Expanded Heating Data .....	16
Airflow Data .....	18
Heat Kit Electrical Specs .....	20
Dimensions .....	21
Wiring Diagrams .....	22
Accessories .....	24

### Standard Features

- Energy-efficient scroll compressor with internal relief valve
- Two-stage cooling on 5-ton units
- Multi-speed ECM indoor blower motor
- All-Aluminum evaporator coil
- Copper tube / aluminum fin condenser coils
- Compressor sound blanket
- Liquid-line filter drier
- Convertible airflow: horizontal or downflow
- Totally enclosed, permanently lubricated condenser fan motor
- Electric heat kit available as a field-installed option
- AHRI certified; ETL listed

### Cabinet Features

- Heavy-gauge, galvanized-steel cabinet with sound control top
- Baked-on powder-paint finish
- Wire fan discharge grille
- Steel louver coil guard
- Top and side maintenance access
- Single-panel access to controls with space provided for field-installed accessories
- When properly anchored, meets the 2010 Florida Building Code unit integrity requirements for hurricane-type winds (Anchor bracket kits available.)



Proper sizing and installation of equipment is critical to achieve optimal performance. Split system air conditioners and heat pumps must be matched with appropriate coil components to meet ENERGY STAR® criteria. Ask your contractor for details or visit [www.energystar.gov](http://www.energystar.gov).

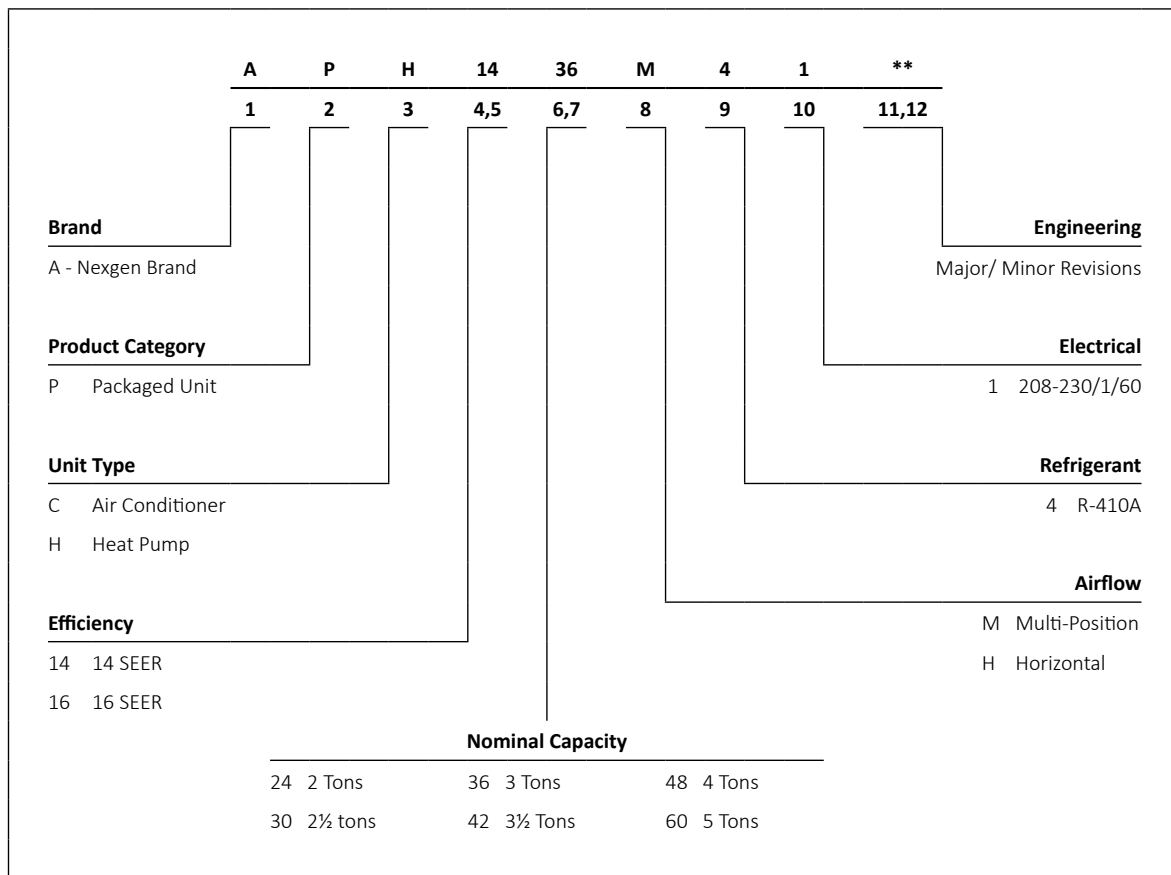

	APH14 24M41A*	APH14 30M41A*	APH14 36M41A*	APH14 42M41A*	APH14 48M41A*	APH14 60M41A*
<b>COOLING CAPACITY</b>						
Total BTU/h	24,000	28,600	34,400	41,000	48,000	58,000
Sensible BTU/h	18,700	21,800	26,200	29,600	36,400	42,500
SEER / EER	14/11	14/11	14/11	14/11	14/11	14/11
Decibels	76	76	81	80	79	80
AHRI #s	7470173	7470174	7470175	7470176	7470177	7470178
<b>HEATING CAPACITY</b>						
BTU/h (47°F)	23,000	28,000	33,200	40,500	45,500	57,000
C.O.P (47°F)	3.6	3.6	3.6	3.6	3.6	3.5
BUT/h (17°F)	12,600	15,000	19,000	22,600	26,600	31,400
C.O.P (17°F)	2.2	2.2	2.2	2.2	2.2	2.2
HSPF	8.0	8.0	8.0	8.0	8.0	8.0
<b>EVAPORATOR MOTOR</b>						
Type	ECM	ECM	ECM	ECM	ECM	ECM
Wheel (D x W)	10 x 9	10 x 9	10 x 9	10 x 9	10 x 9	10 x 9
Nominal Cooling CFM	850	1,050	1,200	1,300	1,600	1,850
FLA	4.3 /--	4.3 /--	4.3 /--	5.8 /--	5.8 /--	7.6 /--
No. of Speeds	5	5	5	5	5	5
Horsepower- RPM	½- 1,050	½- 1,050	½- 1,050	¾- 1,050	¾- 1,050	1- 1,050
<b>EVAPORATOR COIL</b>						
Face Area (ft <sup>2</sup> )	4.55	4.55	4.55	4.55	6.20	6.20
Rows Deep/ Fin per Inch	4 / 14	4 / 14	4 / 14	4 / 14	4 / 14	4 / 14
Drain Size (NPT)	¾"	¾"	¾"	¾"	¾"	¾"
R-410A Refrigerant Charge (oz.)	128	128	115	133	153	180
<b>CONDENSER FAN / COIL</b>						
Horsepower- RPM	¼- 830	¼- 830	¼- 830	¼- 1,075	¼- 1,075	¼- 1,075
FLA/LRA	1.5 / 3.0	1.5 / 3.0	1.4 / 3.0	1.4 / 2.9	1.4 / 2.9	2.5 / 3.0
Fan Diameter / # Fan Blades	22 / 3	22 / 3	22 / 4	22 / 3	22 / 3	22 / 3
Face Area (ft <sup>2</sup> )	12.21	12.21	12.21	12.21	15.30	21.32
Rows Deep/ Fin per Inch	2 / 16	2 / 16	2 / 16	2 / 16	2 / 16	2 / 16
<b>COMPRESSOR</b>						
Quantity	1	1	1	1	1	1
Type	Scroll	Scroll	Scroll	Scroll	Scroll	Scroll
Stage	Single	Single	Single	Single	Single	2 Stage
<b>ELECTRICAL DATA</b>						
Voltage/ Phase (60 Hz)	208-230/1	208-230/1	208-230/1	208-230/1	208-230/1	208-230/1
Compressor RLA/ LRA	12.8 / 58.3	14.1 / 73	16.7 / 79	17.9 / 112	21.8 / 117	27.1 / 152.9
Total Unit Amps	18.6	19.9	22.4	25.1	29	37.2
Min. Circuit Ampacity <sup>1</sup>	21.8	23.4	26.6	29.6	34.5	44.0
Max. Overcurrent Protection <sup>2</sup>	30 amps	35 amps	40 amps	45 amps	50 amps	70 amps
<b>SHIPPING WEIGHT (LBS)</b>						
	380	390	400	410	485	495

<sup>1</sup> Wire size should be determined in accordance with National Electrical Codes. Extensive wire runs will require larger wire sizes.

<sup>2</sup> May use fuses or HACR-type circuit breakers of the same size as noted.

**Note:** Always check the S&R plate for electrical data on the unit being installed.

IDB		OUTDOOR AMBIENT TEMPERATURE																																			
		65°F						75°F						85°F						95°F						105°F						115°F					
		59	63	67	71	59	63	67	71	59	63	67	71	59	63	67	71	59	63	67	71	59	63	67	71	59	63	67	71	59	63	67	71				
70	AIRFLOW	59	63	67	71	59	63	67	71	59	63	67	71	59	63	67	71	59	63	67	71	59	63	67	71	59	63	67	71								
	MBh	23.2	24.0	26.3	-	22.6	23.5	25.7	-	22.1	22.9	25.1	-	21.6	22.3	24.5	-	20.5	21.2	23.3	-	20.5	21.2	23.3	-	19.0	19.7	21.5	-								
	S/T	0.78	0.65	0.45	-	0.81	0.67	0.47	-	0.83	0.69	0.48	-	0.85	0.71	0.49	-	0.89	0.74	0.51	-	0.89	0.74	0.51	-	0.89	0.75	0.52	-								
	ΔT	17	15	11	-	18	15	12	-	18	15	12	-	18	15	12	-	18	15	12	-	18	15	12	-	16	14	11	-								
	kW	1.55	1.58	1.63	-	1.67	1.70	1.75	-	1.77	1.81	1.87	-	1.86	1.90	1.96	-	1.94	1.98	2.05	-	1.94	1.98	2.05	-	2.01	2.05	2.12	-								
	Amps	6.9	7.0	7.2	-	7.3	7.5	7.7	-	7.9	8.0	8.2	-	8.3	8.5	8.7	-	8.7	8.9	9.2	-	8.7	8.9	9.2	-	9.2	9.4	9.7	-								
	HI PR	226	243	257	-	254	273	288	-	288	310	328	-	329	354	373	-	370	398	420	-	370	398	420	-	408	439	464	-								
	LO PR	113	120	131	-	119	127	139	-	124	132	144	-	130	139	151	-	137	145	159	-	137	145	159	-	141	150	164	-								
	MBh	22.8	23.7	25.9	-	22.3	23.1	25.3	-	21.8	22.6	24.7	-	21.2	22.0	24.1	-	20.2	20.9	22.9	-	20.2	20.9	22.9	-	18.7	19.4	21.2	-								
	S/T	0.75	0.62	0.43	-	0.77	0.65	0.45	-	0.79	0.66	0.46	-	0.82	0.68	0.47	-	0.85	0.71	0.49	-	0.85	0.71	0.49	-	0.86	0.72	0.50	-								
ΔT	18	16	12	-	19	16	12	-	19	16	12	-	19	16	12	-	19	16	12	-	19	16	12	-	17	15	11	-									
kW	1.54	1.57	1.62	-	1.66	1.69	1.75	-	1.76	1.80	1.86	-	1.85	1.89	1.95	-	1.93	1.97	2.03	-	1.93	1.97	2.03	-	1.99	2.04	2.11	-									
Amps	6.9	7.0	7.2	-	7.3	7.4	7.6	-	7.8	8.0	8.2	-	8.3	8.4	8.7	-	8.7	8.9	9.1	-	8.7	8.9	9.1	-	9.1	9.3	9.6	-									
HI PR	224	242	255	-	252	271	286	-	286	308	326	-	326	351	371	-	367	395	417	-	367	395	417	-	406	436	461	-									
LO PR	112	119	130	-	119	126	138	-	123	131	143	-	129	138	150	-	136	144	158	-	136	144	158	-	140	149	163	-									
MBh	21.7	22.5	24.6	-	21.2	22.0	24.1	-	20.7	21.4	23.5	-	20.2	20.9	22.9	-	19.2	19.9	21.8	-	19.2	19.9	21.8	-	17.8	18.4	20.2	-									
S/T	0.71	0.60	0.41	-	0.74	0.62	0.43	-	0.76	0.63	0.44	-	0.78	0.65	0.45	-	0.81	0.68	0.47	-	0.81	0.68	0.47	-	0.82	0.69	0.47	-									
ΔT	19	16	12	-	19	17	13	-	19	17	13	-	19	17	13	-	19	17	13	-	19	17	13	-	18	15	12	-									
kW	1.52	1.55	1.59	-	1.63	1.66	1.72	-	1.73	1.77	1.82	-	1.82	1.86	1.92	-	1.90	1.94	2.00	-	1.90	1.94	2.00	-	1.96	2.00	2.07	-									
Amps	6.8	6.9	7.1	-	7.2	7.3	7.5	-	7.7	7.8	8.1	-	8.1	8.3	8.5	-	8.6	8.7	9.0	-	8.6	8.7	9.0	-	9.0	9.2	9.4	-									
HI PR	220	237	250	-	247	266	280	-	281	302	319	-	320	344	363	-	360	387	409	-	360	387	409	-	397	428	452	-									
LO PR	110	117	128	-	116	124	135	-	121	129	140	-	127	135	147	-	133	141	154	-	133	141	154	-	138	146	160	-									

950	MBh	23.6	24.3	26.3	28.2	23.0	23.7	25.7	27.5	22.5	23.1	25.0	26.9	21.9	22.6	24.4	26.2	20.8	21.4	23.2	24.9	19.3	19.9	21.5	23.1				
	S/T	0.89	0.79	0.60	0.4	0.92	0.82	0.62	0.4	0.94	0.84	0.64	0.4	0.97	0.87	0.66	0.4	1.00	0.90	0.68	0.4	1.00	0.91	0.69	0.4				
	ΔT	20	19	15	11	20	19	15	11	20	19	15	11	21	19	16	11	20	19	15	11	20	19	15	11	19	17	14	9.9
	kW	1.56	1.59	1.64	1.7	1.68	1.71	1.77	1.8	1.78	1.82	1.88	1.9	1.88	1.92	1.98	2.0	1.95	2.00	2.06	2.1	2.02	2.07	2.14	2.2				
	Amps	6.9	7.1	7.3	7.5	7.4	7.5	7.7	8.0	7.9	8.1	8.3	8.6	8.4	8.5	8.8	9.1	8.8	9.0	9.3	9.6	9.3	9.5	9.7	10.1				
	HI PR	228	246	259	270.6	256	276	291	303.7	291	314	331	345.4	332	357	377	393.4	373	402	424	442.5	413	444	469	488.9				
	LO PR	114	121	133	141.2	121	128	140	149.2	125	133	146	155.1	132	140	153	162.9	138	147	160	170.7	143	152	166	176.6				
	MBh	23.2	23.9	25.9	27.8	22.7	23.4	25.3	27.1	22.1	22.8	24.7	26.5	21.6	22.2	24.1	25.8	20.5	21.1	22.9	24.5	19.0	19.6	21.2	22.7				
	S/T	0.85	0.76	0.57	0.4	0.88	0.79	0.59	0.4	0.90	0.81	0.61	0.4	0.93	0.83	0.63	0.4	0.97	0.86	0.65	0.4	0.97	0.87	0.66	0.4				
	ΔT	21	20	16	11	22	20	16	11	22	20	16	11	22	20	16	11	21	20	16	11	20	18	15	10.4				
kW	1.55	1.58	1.63	1.7	1.67	1.71	1.76	1.8	1.77	1.81	1.87	1.9	1.87	1.91	1.97	2.0	1.94	1.99	2.05	2.1	2.01	2.06	2.12	2.2					
Amps	6.9	7.0	7.2	7.4	7.4	7.5	7.7	7.9	7.9	8.0	8.3	8.5	8.3	8.5	8.7	9.0	8.8	9.0	9.2	9.5	9.2	9.4	9.7	10.0					
HI PR	227	244	258	268.7	254	274	289	301.6	289	311	329	343.0	330	355	375	390.6	371	399	421	439.4	410	441	466	485.5					
LO PR	113	121	132	140.3	120	127	139	148.2	125	132	145	154.0	131	139	152	161.8	137	146	159	169.5	142	151	165	175.4					
MBh	22.1	22.7	24.6	26.4	21.5	22.2	24.0	25.8	21.0	21.7	23.4	25.2	20.5	21.1	22.9	24.5	19.5	20.1	21.7	23.3	18.1	18.6	20.1	21.6					
S/T	0.81	0.73	0.55	0.4	0.84	0.75	0.57	0.4	0.86	0.77	0.58	0.4	0.89	0.80	0.60	0.4	0.92	0.83	0.63	0.4	0.93	0.83	0.63	0.4					
ΔT	22	20	17	11	22	20	17	12	22	21	17	12	22	21	17	12	22	20	17	12	21	19	16	10.8					
kW	1.53	1.56	1.61	1.7	1.64	1.68	1.73	1.8	1.75	1.78	1.84	1.9	1.84	1.88	1.94	2.0	1.91	1.95	2.02	2.1	1.98	2.02	2.09	2.2					
Amps	6.8	6.9	7.1	7.3	7.2	7.4	7.6	7.8	7.8	7.9	8.1	8.4	8.2	8.4	8.6	8.9	8.6	8.8	9.1	9.4	9.1	9.3	9.5	9.8					
HI PR	222	239	253	263.4	249	268	283	295.5	284	305	322	336.1	323	348	367	382.8	363	391	413	430.7	401	432	456	475.8					
LO PR	111	118	129	137.5	117	125	136	145.2	122	130	142	150.9	128	136	149	158.5	134	143	156	166.1	139	148	161	171.9					

IDB: Entering Indoor Dry Bulb Temperature  
 High & low pressures are measured at the liquid & suction access fittings.  
 Shaded area reflects ACCA (TVA) conditions  
 kW = Total system power  
 Amps = outdoor unit amps (comp. + fans)

IDB		OUTDOOR AMBIENT TEMPERATURE																								
		65°F				75°F				85°F				95°F				105°F				115°F				
		59	63	67	71	59	63	67	71	59	63	67	71	59	63	67	71	59	63	67	71	59	63	67	71	
		ENTERING INDOOR WET BULB TEMPERATURE																								
		MBh	24.0	24.5	26.2	28.0	23.4	23.9	25.6	27.3	22.9	23.4	25.0	26.7	22.3	22.8	24.4	26.0	21.2	21.7	23.1	24.7	19.6	20.1	21.4	22.9
		S/T	0.97	0.91	0.74	0.6	1.00	0.94	0.77	0.6	1.00	0.97	0.79	0.6	1.00	1.00	0.81	0.6	1.00	1.00	0.84	0.6	1.00	1.00	0.85	0.6
		ΔT	23	22	19	15	23	22	19	15	22	22	19	15	22	22	19	15	21	21	19	15	19	19	18	14.1
950		kW	1.57	1.61	1.66	1.7	1.69	1.73	1.78	1.8	1.80	1.84	1.90	2.0	1.89	1.93	2.00	2.1	1.97	2.01	2.08	2.2	2.04	2.09	2.15	2.2
		Amps	7.0	7.1	7.3	7.5	7.4	7.6	7.8	8.0	8.0	8.1	8.4	8.6	8.4	8.6	8.8	9.1	8.9	9.1	9.3	9.6	9.3	9.5	9.8	10.1
		HI PR	231	248	262	273.4	259	279	294	306.7	294	317	334	348.9	335	361	381	397.3	377	406	429	447.0	417	448	474	493.9
		LO PR	115	123	134	142.7	122	130	142	150.7	127	135	147	156.7	133	142	155	164.6	139	148	162	172.4	144	153	167	178.4
		MBh	23.6	24.1	25.8	27.6	23.1	23.6	25.2	26.9	22.5	23.0	24.6	26.3	22.0	22.5	24.0	25.7	20.9	21.3	22.8	24.4	19.3	19.8	21.1	22.6
		S/T	0.93	0.87	0.71	0.5	0.96	0.90	0.74	0.5	0.99	0.93	0.75	0.6	1.00	0.96	0.78	0.6	1.00	0.99	0.81	0.6	1.00	1.00	0.82	0.6
		ΔT	24	23	20	16	24	23	20	16	24	23	20	16	24	23	20	16	23	23	20	16	21	21	19	14.9
80		kW	1.56	1.60	1.65	1.7	1.68	1.72	1.77	1.8	1.79	1.83	1.89	1.9	1.88	1.92	1.99	2.1	1.96	2.00	2.07	2.1	2.03	2.07	2.14	2.2
		Amps	7.0	7.1	7.3	7.5	7.4	7.6	7.8	8.0	7.9	8.1	8.3	8.6	8.4	8.6	8.8	9.1	8.8	9.0	9.3	9.6	9.3	9.5	9.8	10.1
		HI PR	229	246	260	271.5	257	277	292	304.6	292	315	332	346.4	333	358	378	394.6	375	403	426	443.9	414	445	470	490.4
		LO PR	115	122	133	141.7	121	129	141	149.7	126	134	146	155.6	132	141	153	163.4	138	147	161	171.3	143	152	166	177.1
		MBh	22.5	22.9	24.5	26.2	21.9	22.4	23.9	25.6	21.4	21.9	23.4	25.0	20.9	21.3	22.8	24.4	19.8	20.3	21.7	23.2	18.4	18.8	20.1	21.4
		S/T	0.89	0.84	0.68	0.5	0.92	0.87	0.70	0.5	0.95	0.89	0.72	0.5	0.98	0.92	0.75	0.6	1.01	0.95	0.77	0.6	1.02	0.96	0.78	0.6
		ΔT	25	24	20	16	25	24	21	17	25	24	21	17	25	24	21	17	25	24	21	16	23	22	19	15.4
750		kW	1.54	1.57	1.62	1.7	1.66	1.69	1.75	1.8	1.76	1.80	1.86	1.9	1.85	1.89	1.95	2.0	1.93	1.97	2.03	2.1	1.99	2.04	2.11	2.2
		Amps	6.9	7.0	7.2	7.4	7.3	7.4	7.6	7.9	7.8	8.0	8.2	8.4	8.3	8.4	8.7	8.9	8.7	8.9	9.1	9.4	9.1	9.3	9.6	9.9
		HI PR	224	242	255	266.0	252	271	286	298.5	286	308	326	339.5	326	351	371	386.7	367	395	417	435.0	406	436	461	480.6
		LO PR	112	119	130	138.8	119	126	138	146.7	123	131	143	152.5	129	138	150	160.1	136	144	158	167.8	140	149	163	173.6
		MBh	24.4	24.9	26.1	27.8	23.8	24.3	25.5	27.2	23.3	23.7	24.8	26.5	22.7	23.1	24.2	25.9	21.6	22.0	23.0	24.6	20.0	20.4	21.3	22.8
		S/T	1.00	0.98	0.89	0.7	1.00	1.00	0.92	0.7	1.00	1.00	0.94	0.8	1.00	1.00	0.97	0.8	1.00	1.00	1.00	0.8	1.00	1.00	1.00	0.8
		ΔT	24	24	22	19	23	24	23	20	23	23	23	20	22	22	23	20	21	21	22	19	19	20	21	18.2
950		kW	1.59	1.62	1.67	1.7	1.71	1.74	1.80	1.9	1.81	1.85	1.91	2.0	1.91	1.95	2.01	2.1	1.99	2.03	2.10	2.2	2.06	2.10	2.17	2.2
		Amps	7.0	7.2	7.4	7.6	7.5	7.7	7.9	8.1	8.0	8.2	8.4	8.7	8.5	8.7	8.9	9.2	9.0	9.1	9.4	9.7	9.4	9.6	9.9	10.2
		HI PR	233	251	265	276.1	261	281	297	309.8	297	320	338	352.3	339	364	385	401.3	381	410	433	451.5	421	453	478	498.8
		LO PR	116	124	135	144.1	123	131	143	152.2	128	136	149	158.2	134	143	156	166.2	141	150	164	174.2	146	155	169	180.2
		MBh	24.0	24.5	25.7	27.4	23.5	23.9	25.1	26.8	22.9	23.4	24.5	26.1	22.4	22.8	23.9	25.5	21.2	21.7	22.7	24.2	19.7	20.1	21.0	22.4
		S/T	0.98	0.94	0.85	0.7	1.00	0.98	0.88	0.7	1.00	1.00	0.90	0.7	1.00	1.00	0.93	0.8	1.00	1.00	0.97	0.8	1.00	1.00	0.97	0.8
		ΔT	25	25	24	20	25	25	24	21	25	25	24	21	24	25	24	21	23	23	24	21	21	22	22	19.2
850		kW	1.58	1.61	1.66	1.7	1.70	1.73	1.79	1.8	1.80	1.84	1.90	2.0	1.90	1.94	2.00	2.1	1.98	2.02	2.09	2.2	2.04	2.09	2.16	2.2
		Amps	7.0	7.1	7.3	7.6	7.5	7.6	7.8	8.1	8.0	8.2	8.4	8.6	8.5	8.6	8.9	9.2	8.9	9.1	9.4	9.7	9.4	9.6	9.8	10.2
		HI PR	231	249	263	274.2	260	279	295	307.7	295	318	335	349.9	336	362	382	398.5	378	407	430	448.3	418	450	475	495.4
		LO PR	116	123	134	143.1	122	130	142	151.2	127	135	148	157.1	133	142	155	165.0	140	149	162	173.0	145	154	168	178.9
		MBh	22.8	23.3	24.4	26.0	22.3	22.7	23.8	25.4	21.8	22.2	23.3	24.8	21.2	21.7	22.7	24.2	20.2	20.6	21.6	23.0	18.7	19.1	20.0	21.3
		S/T	0.93	0.90	0.81	0.7	0.97	0.93	0.84	0.7	0.99	0.96	0.86	0.7	1.00	0.99	0.89	0.7	1.00	1.00	0.93	0.8	1.00	1.00	0.93	0.8
		ΔT	26	26	24	21	26	26	25	21	27	26	25	21	26	26	25	21	25	25	24	21	23	23	23	19.8
750		kW	1.55	1.58	1.63	1.7	1.67	1.71	1.76	1.8	1.77	1.81	1.87	1.9	1.87	1.91	1.97	2.0	1.94	1.99	2.05	2.1	2.01	2.06	2.12	2.2
		Amps	6.9	7.0	7.2	7.4	7.4	7.5	7.7	7.9	7.9	8.0	8.3	8.5	8.3	8.5	8.7	9.0	8.8	9.0	9.2	9.5	9.2	9.4	9.7	10.0
		HI PR	227	244	258	268.7	254	274	289	301.5	289	311	329	342.9	330	355	374	390.5	371	399	421	439.4	410	441	465	485.4
		LO PR	113	121	132	140.2	120	127	139	148.2	124	132	145	154.0	131	139	152	161.7	137	146	159	169.5	142	151	165	175.3

IDB: Entering Indoor Dry Bulb Temperature  
 High & low pressures are measured at the liquid & suction access fittings.  
 Shaded area reflects AHR1 (TVA) conditions  
 kW = Total system power  
 Amps = outdoor unit amps (comp. + fans)

IDB		OUTDOOR AMBIENT TEMPERATURE																							
		65°F				75°F				85°F				95°F				105°F				115°F			
		59	63	67	71	59	63	67	71	59	63	67	71	59	63	67	71	59	63	67	71	59	63	67	71
70	AIRFLOW	59	63	67	71	59	63	67	71	59	63	67	71	59	63	67	71	59	63	67	71	59	63	67	71
	MBh	27.6	28.6	31.4	-	27.0	28.0	30.6	-	26.3	27.3	29.9	-	25.7	26.6	29.2	-	24.4	25.3	27.7	-	22.6	23.4	25.7	-
	S/T	0.76	0.63	0.44	-	0.79	0.66	0.46	-	0.81	0.67	0.47	-	0.83	0.70	0.48	-	0.87	0.72	0.50	-	0.87	0.73	0.50	-
	ΔT	16	14	11	-	17	14	11	-	17	14	11	-	17	15	11	-	17	14	11	-	15	13	10	-
	kW	1.86	1.90	1.96	-	2.01	2.05	2.12	-	2.13	2.18	2.25	-	2.25	2.30	2.37	-	2.34	2.40	2.48	-	2.43	2.48	2.56	-
	Amps	8.2	8.4	8.6	-	8.8	8.9	9.2	-	9.4	9.6	9.9	-	9.9	10.2	10.4	-	10.5	10.7	11.0	-	11.0	11.3	11.6	-
	HI PR	235	253	267	-	264	284	300	-	300	323	341	-	341	367	388	-	384	413	437	-	424	457	482	-
	LO PR	112	119	130	-	118	126	137	-	123	131	143	-	129	137	150	-	135	144	157	-	140	149	162	-
	MBh	27.2	28.2	30.9	-	26.6	27.5	30.2	-	25.9	26.9	29.5	-	25.3	26.2	28.7	-	24.0	24.9	27.3	-	22.3	23.1	25.3	-
	S/T	0.73	0.61	0.42	-	0.75	0.63	0.44	-	0.77	0.65	0.45	-	0.80	0.67	0.46	-	0.83	0.69	0.48	-	0.84	0.70	0.48	-
ΔT	17	15	11	-	18	15	12	-	18	15	12	-	18	15	12	-	17	15	11	-	16	14	11	-	
kW	1.85	1.89	1.95	-	2.00	2.04	2.11	-	2.12	2.17	2.24	-	2.23	2.28	2.36	-	2.33	2.38	2.46	-	2.41	2.47	2.55	-	
Amps	8.2	8.3	8.6	-	8.7	8.9	9.1	-	9.3	9.5	9.8	-	9.9	10.1	10.4	-	10.4	10.7	11.0	-	11.0	11.2	11.5	-	
HI PR	233	251	265	-	262	282	297	-	298	320	338	-	339	365	385	-	381	411	434	-	421	454	479	-	
LO PR	111	118	129	-	117	125	136	-	122	130	142	-	128	136	149	-	134	143	156	-	139	148	161	-	
MBh	25.1	26.0	28.5	-	24.5	25.4	27.9	-	23.9	24.8	27.2	-	23.4	24.2	26.5	-	22.2	23.0	25.2	-	20.6	21.3	23.3	-	
S/T	0.70	0.59	0.41	-	0.73	0.61	0.42	-	0.75	0.62	0.43	-	0.77	0.64	0.45	-	0.80	0.67	0.46	-	0.81	0.67	0.47	-	
ΔT	18	15	12	-	18	15	12	-	18	15	12	-	18	16	12	-	18	15	12	-	17	14	11	-	
kW	1.81	1.85	1.90	-	1.95	1.99	2.05	-	2.07	2.12	2.18	-	2.18	2.23	2.30	-	2.27	2.32	2.40	-	2.35	2.40	2.48	-	
Amps	8.0	8.1	8.4	-	8.5	8.7	8.9	-	9.1	9.3	9.6	-	9.7	9.9	10.1	-	10.2	10.4	10.7	-	10.7	10.9	11.3	-	
HI PR	226	244	257	-	254	273	289	-	289	311	328	-	329	354	374	-	370	398	420	-	409	440	465	-	
LO PR	108	115	125	-	114	121	132	-	118	126	137	-	124	132	144	-	130	139	151	-	135	143	157	-	

75	AIRFLOW	59	63	67	71	59	63	67	71	59	63	67	71	59	63	67	71	59	63	67	71	59	63	67	71
	MBh	28.1	28.9	31.3	33.6	27.4	28.2	30.6	32.8	26.8	27.6	29.8	32.0	26.1	26.9	29.1	31.2	24.8	25.6	27.7	29.7	23.0	23.7	25.6	27.5
	S/T	0.86	0.77	0.58	0.4	0.90	0.80	0.61	0.4	0.92	0.82	0.62	0.4	0.95	0.85	0.64	0.4	0.98	0.88	0.67	0.4	0.99	0.89	0.67	0.4
	ΔT	19	17	14	10	19	18	15	10	19	18	15	10	19	18	15	10	19	18	14	10	18	16	13	9.3
	kW	1.88	1.92	1.98	2.0	2.02	2.07	2.14	2.2	2.15	2.20	2.27	2.3	2.27	2.32	2.39	2.5	2.36	2.42	2.50	2.6	2.45	2.50	2.59	2.7
	Amps	8.3	8.4	8.7	8.9	8.8	9.0	9.3	9.5	9.5	9.7	9.9	10.3	10.0	10.2	10.5	10.9	10.6	10.8	11.1	11.5	11.1	11.4	11.7	12.1
	HI PR	237	255	270	281.3	266	287	303	315.6	303	326	344	359.0	345	371	392	408.8	388	418	441	460.0	429	461	487	508.2
	LO PR	113	120	131	139.8	119	127	139	147.7	124	132	144	153.5	130	139	151	161.3	137	145	159	169.0	141	150	164	174.8
	MBh	27.7	28.5	30.8	33.1	27.0	27.8	30.1	32.3	26.4	27.2	29.4	31.6	25.7	26.5	28.7	30.8	24.5	25.2	27.3	29.2	22.7	23.3	25.2	27.1
	S/T	0.83	0.74	0.56	0.4	0.86	0.77	0.58	0.4	0.88	0.79	0.60	0.4	0.91	0.81	0.61	0.4	0.94	0.84	0.64	0.4	0.95	0.85	0.64	0.4
ΔT	20	18	15	10	20	19	15	11	20	19	15	11	20	19	15	11	20	19	15	11	19	17	14	9.8	
kW	1.87	1.91	1.97	2.0	2.01	2.06	2.12	2.2	2.14	2.19	2.26	2.3	2.25	2.30	2.38	2.5	2.35	2.40	2.48	2.6	2.43	2.49	2.57	2.7	
Amps	8.2	8.4	8.6	8.9	8.8	9.0	9.2	9.5	9.4	9.6	9.9	10.2	10.0	10.2	10.5	10.8	10.5	10.7	11.1	11.4	11.1	11.3	11.6	12.0	
HI PR	236	254	268	279.3	264	285	301	313.4	301	324	342	356.5	343	369	389	406.0	385	415	438	456.8	426	458	484	504.7	
LO PR	112	119	130	138.9	119	126	138	146.7	123	131	143	152.5	129	138	150	160.2	136	144	158	167.8	140	149	163	173.6	
MBh	25.5	26.3	28.5	30.5	24.9	25.7	27.8	29.8	24.4	25.1	27.1	29.1	23.8	24.5	26.5	28.4	22.6	23.2	25.2	27.0	20.9	21.5	23.3	25.0	
S/T	0.80	0.71	0.54	0.3	0.83	0.74	0.56	0.4	0.85	0.76	0.57	0.4	0.88	0.78	0.59	0.4	0.91	0.81	0.61	0.4	0.92	0.82	0.62	0.4	
ΔT	20	19	15	11	21	19	16	11	21	19	16	11	21	19	16	11	20	19	15	11	19	18	14	10.0	
kW	1.82	1.86	1.92	2.0	1.96	2.01	2.07	2.1	2.09	2.13	2.20	2.3	2.20	2.25	2.32	2.4	2.29	2.34	2.42	2.5	2.37	2.42	2.50	2.6	
Amps	8.0	8.2	8.4	8.7	8.6	8.7	9.0	9.3	9.2	9.4	9.6	10.0	9.7	9.9	10.2	10.6	10.3	10.5	10.8	11.1	10.8	11.0	11.3	11.7	
HI PR	229	246	260	271.0	257	276	291	304.0	292	314	332	345.8	332	358	378	393.8	374	402	425	443.1	413	444	469	489.5	
LO PR	109	116	126	134.7	115	122	134	142.3	120	127	139	147.9	126	134	146	155.4	132	140	153	162.8	136	145	158	168.4	

IDB: Entering Indoor Dry Bulb Temperature  
 High & low pressures are measured at the liquid & suction access fittings.  
 Shaded area reflects ACCA (TVA) conditions  
 kW = Total system power  
 Amps = outdoor unit amps (comp. + fans)

IDB	AIRFLOW	OUTDOOR AMBIENT TEMPERATURE																																			
		65°F						75°F						85°F						95°F						105°F						115°F					
		59	63	67	71	59	63	67	71	59	63	67	71	59	63	67	71	59	63	67	71	59	63	67	71	59	63	67	71								
80	MBh	28.6	29.2	31.2	33.4	27.9	28.5	30.5	32.6	27.3	27.9	29.8	31.8	26.6	27.2	29.0	31.0	25.3	25.8	27.6	29.5	23.4	23.9	25.5	27.3												
	S/T	0.95	0.89	0.72	0.5	0.98	0.92	0.75	0.6	1.00	0.94	0.77	0.6	1.00	0.98	0.79	0.6	1.00	1.00	0.82	0.6	1.00	1.00	0.83	0.6												
	ΔT	21	20	18	14	21	21	18	14	21	21	18	14	21	21	18	14	20	20	18	14	18	19	17	13.3												
	kW	1.89	1.93	2.00	2.1	2.04	2.09	2.15	2.2	2.17	2.22	2.29	2.4	2.29	2.34	2.41	2.5	2.38	2.44	2.52	2.6	2.47	2.52	2.61	2.7												
	Amps	8.3	8.5	8.7	9.0	8.9	9.1	9.3	9.6	9.5	9.7	10.0	10.3	10.1	10.3	10.6	11.0	10.7	10.9	11.2	11.6	11.2	11.5	11.8	12.2												
	HI PR	240	258	272	284.1	269	289	306	318.8	306	329	348	362.6	348	375	396	413.0	392	422	445	464.6	433	466	492	513.3												
	LO PR	114	121	133	141.2	121	128	140	149.2	125	133	146	155.1	132	140	153	162.9	138	147	160	170.7	143	152	166	176.6												
	MBh	28.2	28.8	30.7	32.9	27.5	28.1	30.0	32.1	26.9	27.4	29.3	31.3	26.2	26.8	28.6	30.6	24.9	25.4	27.2	29.0	23.1	23.6	25.2	26.9												
	S/T	0.91	0.85	0.69	0.5	0.94	0.88	0.72	0.5	0.96	0.90	0.74	0.6	1.00	0.93	0.76	0.6	1.00	1.00	0.79	0.6	1.00	1.00	0.80	0.6												
	ΔT	22	21	19	15	23	22	19	15	23	22	19	15	23	22	19	15	22	22	19	15	20	20	18	14.0												
kW	1.88	1.92	1.98	2.0	2.03	2.07	2.14	2.2	2.16	2.21	2.28	2.4	2.27	2.32	2.40	2.5	2.37	2.42	2.50	2.6	2.45	2.51	2.59	2.7													
Amps	8.3	8.5	8.7	9.0	8.8	9.0	9.3	9.6	9.5	9.7	10.0	10.3	10.0	10.3	10.6	10.9	10.6	10.8	11.1	11.5	11.2	11.4	11.7	12.1													
HI PR	238	256	271	282.2	267	287	304	316.6	304	327	345	360.1	346	372	393	410.1	389	419	442	461.4	430	463	489	509.8													
LO PR	113	121	132	140.3	120	127	139	148.2	125	132	145	154.0	131	139	152	161.8	137	146	159	169.5	142	151	165	175.4													
MBh	26.0	26.6	28.4	30.3	25.4	25.9	27.7	29.6	24.8	25.3	27.1	28.9	24.2	24.7	26.4	28.2	23.0	23.5	25.1	26.8	21.3	21.7	23.2	24.8													
S/T	0.88	0.82	0.67	0.5	0.91	0.85	0.69	0.5	0.93	0.87	0.71	0.5	0.96	0.90	0.73	0.5	1.00	0.93	0.76	0.6	1.00	0.94	0.77	0.6													
ΔT	23	22	19	15	23	22	19	15	23	22	19	15	23	22	19	15	23	22	19	15	21	20	18	14.2													
kW	1.84	1.88	1.94	2.0	1.98	2.02	2.09	2.2	2.10	2.15	2.22	2.3	2.22	2.26	2.34	2.4	2.31	2.36	2.44	2.5	2.39	2.44	2.53	2.6													
Amps	8.1	8.3	8.5	8.7	8.6	8.8	9.1	9.3	9.3	9.5	9.7	10.0	9.8	10.0	10.3	10.6	10.3	10.6	10.9	11.2	10.9	11.1	11.4	11.8													
HI PR	231	248	262	273.7	259	279	294	307.1	295	317	335	349.3	336	361	381	397.8	378	406	429	447.5	417	449	474	494.5													
LO PR	110	117	128	136.0	116	124	135	143.7	121	128	140	149.4	127	135	147	156.9	133	141	154	164.5	138	146	160	170.1													
85	MBh	29.1	29.6	31.1	33.1	28.4	29.0	30.3	32.4	27.7	28.3	29.6	31.6	27.1	27.6	28.9	30.8	25.7	26.2	27.4	29.3	23.8	24.3	25.4	27.1												
	S/T	0.99	0.96	0.87	0.7	1.00	0.99	0.90	0.7	1.00	0.98	0.88	0.7	1.00	1.00	0.95	0.8	1.00	1.00	0.99	0.8	1.00	1.00	0.99	0.8												
	ΔT	23	22	21	18	22	23	21	18	22	22	21	18	21	22	21	19	20	20	21	18	19	19	20	17.1												
	kW	1.91	1.95	2.01	2.1	2.06	2.10	2.17	2.2	2.19	2.24	2.31	2.4	2.30	2.36	2.43	2.5	2.40	2.46	2.54	2.6	2.49	2.54	2.63	2.7												
	Amps	8.4	8.6	8.8	9.1	9.0	9.1	9.4	9.7	9.6	9.8	10.1	10.4	10.2	10.4	10.7	11.1	10.7	11.0	11.3	11.7	11.3	11.6	11.9	12.3												
	HI PR	242	261	275	287.0	272	292	309	322.0	309	333	351	366.2	352	379	400	417.1	396	426	450	469.2	437	471	497	518.5												
	LO PR	115	123	134	142.7	122	130	142	150.7	127	135	147	156.6	133	142	154	164.5	139	148	162	172.4	144	153	167	178.4												
	MBh	28.7	29.2	30.6	32.6	28.0	28.5	29.9	31.9	27.3	27.9	29.2	31.1	26.7	27.2	28.5	30.4	25.3	25.8	27.0	28.8	23.5	23.9	25.0	26.7												
	S/T	0.95	0.92	0.83	0.7	0.99	0.95	0.86	0.7	1.00	0.98	0.88	0.7	1.00	1.00	0.91	0.7	1.00	1.00	0.94	0.8	1.00	1.00	0.95	0.8												
	ΔT	24	23	22	19	24	24	22	19	24	24	22	19	23	24	23	20	22	23	22	19	21	21	21	18.1												
kW	1.90	1.94	2.00	2.1	2.05	2.09	2.16	2.2	2.18	2.22	2.30	2.4	2.29	2.34	2.42	2.5	2.39	2.44	2.52	2.6	2.47	2.53	2.61	2.7													
Amps	8.4	8.5	8.8	9.0	8.9	9.1	9.3	9.6	9.6	9.8	10.0	10.4	10.1	10.3	10.6	11.0	10.7	10.9	11.2	11.6	11.2	11.5	11.8	12.2													
HI PR	240	259	273	285.0	270	290	307	319.8	307	330	349	363.7	349	376	397	414.2	393	423	447	466.0	434	467	494	514.9													
LO PR	115	122	133	141.7	121	129	141	149.7	126	134	146	155.5	132	141	153	163.4	138	147	161	171.2	143	152	166	177.1													
MBh	26.4	27.0	28.2	30.1	25.8	26.3	27.6	29.4	25.2	25.7	26.9	28.7	24.6	25.1	26.3	28.0	23.4	23.8	25.0	26.6	21.7	22.1	23.1	24.7													
S/T	0.92	0.89	0.80	0.6	0.95	0.92	0.83	0.7	0.97	0.94	0.85	0.7	1.00	0.97	0.88	0.7	1.00	1.00	0.91	0.7	1.00	1.00	0.92	0.7													
ΔT	24	24	23	20	25	24	23	20	25	24	23	20	25	24	23	20	23	24	23	20	22	22	22	21	18.3												
kW	1.85	1.89	1.95	2.0	2.00	2.04	2.10	2.2	2.12	2.17	2.24	2.3	2.23	2.28	2.36	2.4	2.33	2.38	2.46	2.5	2.41	2.46	2.55	2.6													
Amps	8.2	8.3	8.6	8.8	8.7	8.9	9.1	9.4	9.3	9.5	9.8	10.1	9.9	10.1	10.4	10.7	10.4	10.7	11.0	11.3	11.0	11.2	11.5	11.9													
HI PR	233	251	265	276.4	262	282	297	310.2	298	320	338	352.8	339	365	385	401.8	381	410	433	452.0	421	453	479	499.4													
LO PR	111	118	129	137.4	117	125	136	145.2	122	130	142	150.9	128	136	149	158.5	134	143	156	166.1	139	148	161	171.8													

IDB: Entering Indoor Dry Bulb Temperature  
 High & low pressures are measured at the liquid & suction access fittings.  
 Shaded area reflects AHRl (TVA) conditions  
 kW = Total system power  
 Amps = outdoor unit amps (comp. + fans)

IDB		OUTDOOR AMBIENT TEMPERATURE																																			
		65°F						75°F						85°F						95°F						105°F						115°F					
		59	63	67	71	59	63	67	71	59	63	67	71	59	63	67	71	59	63	67	71	59	63	67	71	59	63	67	71	59	63	67	71				
70	1350	MBh	33.7	34.9	38.3	-	32.9	34.1	37.4	-	32.1	33.3	36.5	-	31.4	32.5	35.6	-	29.8	30.9	33.8	-	27.6	28.6	31.3	-	29.8	30.9	33.8	-	27.6	28.6	31.3	-			
		S/T	0.76	0.64	0.44	-	0.79	0.66	0.46	-	0.81	0.68	0.47	-	0.84	0.70	0.48	-	0.87	0.72	0.50	-	0.87	0.73	0.51	-	0.87	0.72	0.50	-	0.87	0.73	0.51	-			
		ΔT	17	15	11	-	18	15	12	-	18	15	12	-	18	15	12	-	18	15	12	-	16	14	11	-	18	15	12	-	16	14	11	-			
		kW	2.35	2.40	2.47	-	2.53	2.58	2.67	-	2.69	2.75	2.84	-	2.83	2.89	2.99	-	2.95	3.02	3.12	-	3.05	3.12	3.23	-	2.95	3.02	3.12	-	3.05	3.12	3.23	-			
		Amps	10.4	10.6	10.9	-	11.1	11.3	11.6	-	11.9	12.2	12.5	-	12.6	12.9	13.2	-	13.3	13.6	14.0	-	14.0	14.3	14.7	-	13.3	13.6	14.0	-	14.0	14.3	14.7	-			
	1200	HI PR	242	260	275	-	271	292	308	-	309	332	351	-	351	378	399	-	395	426	449	-	437	470	496	-	395	426	449	-	437	470	496	-			
		LO PR	111	118	129	-	118	125	137	-	122	130	142	-	128	137	149	-	135	143	156	-	139	148	162	-	135	143	156	-	139	148	162	-			
		MBh	32.7	33.9	37.2	-	32.0	33.1	36.3	-	31.2	32.3	35.4	-	30.4	31.6	34.6	-	28.9	30.0	32.8	-	26.8	27.8	30.4	-	28.9	30.0	32.8	-	26.8	27.8	30.4	-			
		S/T	0.73	0.61	0.42	-	0.75	0.63	0.44	-	0.77	0.64	0.45	-	0.80	0.67	0.46	-	0.83	0.69	0.48	-	0.83	0.70	0.48	-	0.83	0.69	0.48	-	0.83	0.70	0.48	-			
		ΔT	18	16	12	-	18	16	12	-	18	16	12	-	19	16	12	-	18	16	12	-	17	15	11	-	18	16	12	-	17	15	11	-			
1050	kW	2.33	2.38	2.46	-	2.51	2.56	2.65	-	2.67	2.73	2.82	-	2.81	2.87	2.96	-	2.93	2.99	3.09	-	3.03	3.10	3.20	-	2.93	2.99	3.09	-	3.03	3.10	3.20	-				
	Amps	10.3	10.5	10.8	-	11.0	11.2	11.5	-	11.8	12.1	12.4	-	12.5	12.8	13.1	-	13.2	13.5	13.9	-	13.9	14.2	14.6	-	13.2	13.5	13.9	-	13.9	14.2	14.6	-				
	HI PR	239	258	272	-	269	289	305	-	306	329	347	-	348	375	395	-	392	421	445	-	433	466	492	-	392	421	445	-	433	466	492	-				
	LO PR	110	117	128	-	116	124	135	-	121	129	141	-	127	135	148	-	133	142	155	-	138	147	160	-	133	142	155	-	138	147	160	-				
	MBh	30.2	31.3	34.3	-	29.5	30.6	33.5	-	28.8	29.9	32.7	-	28.1	29.1	31.9	-	26.7	27.7	30.3	-	24.7	25.6	28.1	-	26.7	27.7	30.3	-	24.7	25.6	28.1	-				

75	1350	MBh	34.3	35.3	38.2	41.0	33.5	34.5	37.3	40.0	32.7	33.7	36.4	39.1	31.9	32.8	35.5	38.1	30.3	31.2	33.8	36.2	28.1	28.9	31.3	33.6
		S/T	0.87	0.77	0.59	0.4	0.90	0.80	0.61	0.4	0.92	0.82	0.62	0.4	0.95	0.85	0.64	0.4	0.99	0.88	0.67	0.4	0.99	0.89	0.67	0.4
		ΔT	20	19	15	11	20	19	15	11	20	19	15	11	21	19	16	11	20	19	15	11	19	17	14	9.9
		kW	2.37	2.42	2.50	2.6	2.55	2.61	2.69	2.8	2.71	2.77	2.86	3.0	2.86	2.92	3.01	3.1	2.98	3.04	3.14	3.3	3.08	3.15	3.26	3.4
		Amps	10.5	10.7	11.0	11.3	11.2	11.4	11.7	12.1	12.0	12.2	12.6	13.0	12.7	13.0	13.4	13.8	13.4	13.7	14.1	14.6	14.1	14.4	14.8	15.4
	1200	HI PR	244	263	278	289.5	274	295	311	324.9	312	335	354	369.5	355	382	403	420.8	399	430	454	473.4	441	475	502	523.1
		LO PR	112	120	131	139.0	119	126	138	146.9	123	131	143	152.7	130	138	151	160.4	136	145	158	168.1	141	150	163	173.8
		MBh	33.3	34.3	37.1	39.8	32.5	33.5	36.2	38.9	31.7	32.7	35.4	38.0	31.0	<b>31.9</b>	34.5	37.0	29.4	30.3	32.8	35.2	27.2	28.1	30.4	32.6
		S/T	0.83	0.74	0.56	0.4	0.86	0.77	0.58	0.4	0.88	0.78	0.59	0.4	0.91	<b>0.81</b>	0.61	0.4	0.94	0.84	0.64	0.4	0.95	0.85	0.64	0.4
		ΔT	21	19	16	11	21	20	16	11	21	20	16	11	21	20	16	11	21	20	16	11	20	18	15	10.3
1050	kW	2.35	2.40	2.48	2.6	2.53	2.59	2.67	2.8	2.69	2.75	2.84	2.9	2.83	<b>2.89</b>	2.99	3.1	2.95	3.02	3.12	3.2	3.05	3.12	3.23	3.3	
	Amps	10.4	10.6	10.9	11.2	11.1	11.3	11.6	12.0	11.9	12.2	12.5	12.9	12.6	<b>12.9</b>	13.2	13.7	13.3	13.6	14.0	14.5	14.0	14.3	14.7	15.2	
	HI PR	242	260	275	286.7	271	292	308	321.7	309	332	351	365.8	352	<b>378</b>	399	416.7	396	426	449	468.8	437	470	497	517.9	
	LO PR	111	118	129	137.7	118	125	137	145.4	122	130	142	151.2	128	<b>137</b>	149	158.8	135	143	156	166.4	139	148	162	172.1	
	MBh	30.7	31.6	34.2	36.7	30.0	30.9	33.4	35.9	29.3	30.2	32.6	35.0	28.6	29.4	31.8	34.2	27.1	28.0	30.3	32.5	25.1	25.9	28.0	30.1	

IDB: Entering Indoor Dry Bulb Temperature  
 High & low pressures are measured at the liquid & suction access fittings.  
 Shaded area reflects ACCA (TVA) conditions  
 kW = Total system power  
 Amps = outdoor unit amps (comp. + fans)



IDB		OUTDOOR AMBIENT TEMPERATURE																																				
		65°F						75°F						85°F						95°F						105°F						115°F						
		AIRFLOW			59			63			67			71			59			63			67			71			59			63			67			71
		ENTERING INDOOR WET BULB TEMPERATURE																																				
80	1350	MBh	34.9	35.7	38.1	40.7	34.1	34.8	37.2	39.8	33.3	34.0	36.3	38.8	32.5	33.2	35.4	37.9	30.8	31.5	33.7	36.0	28.6	29.2	31.2	33.3												
		S/T	0.95	0.89	0.72	0.5	1.00	0.92	0.75	0.6	1.00	0.95	0.77	0.6	1.00	1.00	0.80	0.6	1.00	1.00	0.83	0.6	1.00	1.00	0.83	0.6												
	ΔT	23	22	19	15	23	22	19	15	23	22	19	15	23	23	19	15	23	21	21	19	15	19	20	18	14.1												
	kW	2.39	2.44	2.52	2.6	2.57	2.63	2.71	2.8	2.74	2.80	2.89	3.0	2.88	2.94	3.04	3.1	3.00	3.07	3.17	3.3	3.11	3.18	3.28	3.4													
	Amps	10.5	10.8	11.1	11.4	11.3	11.5	11.8	12.2	12.1	12.3	12.7	13.1	12.8	13.1	13.5	13.9	13.5	13.8	14.2	14.7	14.2	14.5	15.0	15.5													
	HI PR	247	266	280	292.5	277	298	315	328.2	315	339	358	373.2	359	386	408	425.1	403	434	459	478.2	446	480	507	528.4													
	LO PR	114	121	132	140.4	120	139	148.4	125	133	145	154.2	131	139	152	162.0	137	146	159	169.8	142	151	165	175.6														
	MBh	33.9	34.6	37.0	39.5	33.1	33.8	36.1	38.6	32.3	33.0	35.3	37.7	31.5	32.2	34.4	36.8	29.9	30.6	32.7	34.9	27.7	28.3	30.3	32.4													
	S/T	0.91	0.85	0.69	0.5	0.94	0.88	0.72	0.5	0.96	0.90	0.73	0.5	0.99	0.93	0.76	0.6	1.00	0.97	0.79	0.6	1.00	0.98	0.79	0.6													
	ΔT	24	23	20	16	24	23	20	16	24	23	20	16	24	23	20	16	23	23	20	16	21	21	18	14.7													
kW	2.37	2.42	2.50	2.6	2.55	2.61	2.69	2.8	2.71	2.77	2.86	3.0	2.86	2.92	3.02	3.1	2.98	3.04	3.14	3.3	3.08	3.15	3.26	3.4														
Amps	10.5	10.7	11.0	11.3	11.2	11.4	11.7	12.1	12.0	12.2	12.6	13.0	12.7	13.0	13.4	13.8	13.4	13.7	14.1	14.6	14.1	14.4	14.9	15.4														
HI PR	244	263	278	289.6	274	295	312	324.9	312	336	354	369.5	355	382	404	420.9	399	430	454	473.5	441	475	502	523.2														
LO PR	113	120	131	139.1	119	126	138	146.9	123	131	143	152.7	130	138	151	160.4	136	145	158	168.1	141	150	163	173.9														
MBh	31.2	31.9	34.1	36.5	30.5	31.2	33.3	35.6	29.8	30.5	32.5	34.8	29.1	29.7	31.8	33.9	27.6	28.2	30.2	32.2	25.6	26.2	27.9	29.9														
S/T	0.87	0.82	0.67	0.5	0.90	0.85	0.69	0.5	0.93	0.87	0.71	0.5	0.96	0.90	0.73	0.5	0.99	0.93	0.76	0.6	1.00	0.94	0.77	0.6														
ΔT	24	23	20	16	24	23	20	16	24	23	20	16	24	23	20	16	24	23	20	16	22	22	19	15.0														
kW	2.31	2.36	2.43	2.5	2.49	2.54	2.62	2.7	2.65	2.70	2.79	2.9	2.78	2.85	2.94	3.0	2.90	2.97	3.06	3.2	3.00	3.07	3.17	3.3														
Amps	10.2	10.4	10.7	11.1	10.9	11.1	11.5	11.8	11.7	12.0	12.3	12.7	12.4	12.7	13.0	13.5	13.1	13.4	13.8	14.2	13.8	14.1	14.5	15.0														
HI PR	237	255	269	280.9	266	286	302	315.2	302	325	344	358.5	344	371	391	408.3	388	417	440	459.3	428	461	487	507.5														
LO PR	109	116	127	134.9	115	123	134	142.5	120	127	139	148.1	126	134	146	155.6	132	140	153	163.0	136	145	158	168.6														
85	1350	MBh	35.5	36.2	37.9	40.4	34.7	35.3	37.0	39.5	33.8	34.5	36.1	38.6	33.0	33.7	35.3	37.6	31.4	32.0	33.5	35.7	29.1	29.6	31.0	33.1												
		S/T	1.00	0.96	0.87	0.7	1.00	1.00	0.90	0.7	1.00	1.00	0.92	0.7	1.00	1.00	0.95	0.8	1.00	1.00	0.99	0.8	1.00	1.00	1.00	0.8												
	ΔT	24	24	22	19	24	24	23	20	23	23	23	20	22	23	23	20	22	23	23	19	20	20	21	18.2													
	kW	2.41	2.46	2.54	2.6	2.59	2.65	2.73	2.8	2.76	2.82	2.91	3.0	2.90	2.97	3.07	3.2	3.03	3.09	3.20	3.3	3.13	3.20	3.31	3.4													
	Amps	10.6	10.8	11.1	11.5	11.4	11.6	11.9	12.3	12.2	12.4	12.8	13.2	12.9	13.2	13.6	14.0	13.6	13.9	14.3	14.8	14.3	14.7	15.1	15.6													
	HI PR	249	268	283	295.4	280	301	318	331.5	318	342	361	377.0	362	390	412	429.3	408	439	463	483.0	450	485	512	533.7													
	LO PR	115	122	133	141.9	121	129	141	149.9	126	134	146	155.8	132	141	154	163.6	139	147	161	171.5	143	153	167	177.4													
	MBh	34.5	35.1	36.8	39.3	33.7	34.3	35.9	38.3	32.9	33.5	35.1	37.4	32.1	32.7	34.2	36.5	30.5	31.0	32.5	34.7	28.2	28.8	30.1	32.1													
	S/T	0.95	0.92	0.83	0.7	0.98	0.95	0.86	0.7	1.00	0.97	0.88	0.7	1.00	1.00	0.91	0.7	1.00	1.00	0.94	0.8	1.00	1.00	0.95	0.8													
	ΔT	25	25	23	20	25	25	24	20	25	25	24	20	25	25	24	21	23	24	23	20	22	22	22	19.0													
kW	2.39	2.44	2.52	2.6	2.57	2.63	2.71	2.8	2.74	2.80	2.89	3.0	2.88	2.94	3.04	3.1	3.00	3.07	3.17	3.3	3.11	3.18	3.28	3.4														
Amps	10.5	10.8	11.1	11.4	11.3	11.5	11.8	12.2	12.1	12.3	12.7	13.1	12.8	13.1	13.5	13.9	13.5	13.8	14.2	14.7	14.2	14.5	15.0	15.5														
HI PR	247	266	280	292.5	277	298	315	328.2	315	339	358	373.2	359	386	408	425.1	403	434	459	478.2	446	480	507	528.4														
LO PR	114	121	132	140.4	120	139	148.4	125	133	145	154.2	131	139	152	162.0	137	146	159	169.8	142	151	165	175.6															
MBh	31.8	32.4	34.0	36.2	31.1	31.7	33.2	35.4	30.3	30.9	32.4	34.5	29.6	30.2	31.6	33.7	28.1	28.7	30.0	32.0	26.0	26.5	27.8	29.7														
S/T	0.92	0.88	0.80	0.6	0.95	0.92	0.83	0.7	0.97	0.94	0.85	0.7	1.00	0.97	0.87	0.7	1.00	1.00	0.91	0.7	1.00	1.00	0.92	0.7														
ΔT	25	25	24	21	26	25	24	21	26	25	24	21	26	26	24	21	25	25	24	21	23	23	22	19.3														
kW	2.33	2.38	2.45	2.5	2.51	2.56	2.65	2.7	2.67	2.73	2.81	2.9	2.81	2.87	2.96	3.1	2.93	2.99	3.09	3.2	3.03	3.10	3.20	3.3														
Amps	10.3	10.5	10.8	11.1	11.0	11.2	11.5	11.9	11.8	12.1	12.4	12.8	12.5	12.8	13.1	13.6	13.2	13.5	13.9	14.3	13.9	14.2	14.6	15.1														
HI PR	239	258	272	283.7	269	289	305	318.3	305	329	347	362.0	348	374	395	412.3	391	421	445	463.9	432	465	491	512.5														
LO PR	110	117	128	136.2	116	124	135	143.9	121	129	140	149.6	127	135	148	157.1	133	142	155	164.7	138	147	160	170.3														

IDB: Entering Indoor Dry Bulb Temperature  
 High & low pressures are measured at the liquid & suction access fittings.  
 Shaded area reflects AHRl (TVA) conditions  
 kW = Total system power  
 Amps = outdoor unit amps (comp. + fans)

IDB	AIRFLOW	OUTDOOR AMBIENT TEMPERATURE																								
		65°F				75°F				85°F				95°F				105°F				115°F				
		59	63	67	71	59	63	67	71	59	63	67	71	59	63	67	71	59	63	67	71	59	63	67	71	
70	1350	MBh	33.7	34.9	38.3	-	32.9	34.1	37.4	-	32.1	33.3	36.5	-	31.4	32.5	35.6	-	29.8	30.9	33.8	-	27.6	28.6	31.3	-
		S/T	0.76	0.64	0.44	-	0.79	0.66	0.46	-	0.81	0.68	0.47	-	0.84	0.70	0.48	-	0.87	0.72	0.50	-	0.87	0.73	0.51	-
	ΔT	17	15	11	-	18	15	12	-	18	15	12	-	18	15	12	-	18	15	12	-	16	14	11	-	
	kW	2.35	2.40	2.47	-	2.53	2.58	2.67	-	2.69	2.75	2.84	-	2.83	2.89	2.99	-	2.95	3.02	3.12	-	3.05	3.12	3.23	-	
	Amps	10.4	10.6	10.9	-	11.1	11.3	11.6	-	11.9	12.2	12.5	-	12.6	12.9	13.2	-	13.3	13.6	14.0	-	14.0	14.3	14.7	-	
	HI PR	242	260	275	-	271	292	308	-	309	332	351	-	351	378	399	-	395	426	449	-	437	470	496	-	
	LO PR	111	118	129	-	118	125	137	-	122	130	142	-	128	137	149	-	135	143	156	-	139	148	162	-	
	MBh	32.7	33.9	37.2	-	32.0	33.1	36.3	-	31.2	32.3	35.4	-	30.4	31.6	34.6	-	28.9	30.0	32.8	-	26.8	27.8	30.4	-	
	S/T	0.73	0.61	0.42	-	0.75	0.63	0.44	-	0.77	0.64	0.45	-	0.80	0.67	0.46	-	0.83	0.69	0.48	-	0.83	0.70	0.48	-	
	ΔT	18	16	12	-	18	16	12	-	18	16	12	-	19	16	12	-	18	16	12	-	17	15	11	-	
kW	2.33	2.38	2.46	-	2.51	2.56	2.65	-	2.67	2.73	2.82	-	2.81	2.87	2.96	-	2.93	2.99	3.09	-	3.03	3.10	3.20	-		
Amps	10.3	10.5	10.8	-	11.0	11.2	11.5	-	11.8	12.1	12.4	-	12.5	12.8	13.1	-	13.2	13.5	13.9	-	13.9	14.2	14.6	-		
HI PR	239	258	272	-	269	289	305	-	306	329	347	-	348	375	395	-	392	421	445	-	433	466	492	-		
LO PR	110	117	128	-	116	124	135	-	121	129	141	-	127	135	148	-	133	142	155	-	138	147	160	-		
MBh	30.2	31.3	34.3	-	29.5	30.6	33.5	-	28.8	29.9	32.7	-	28.1	29.1	31.9	-	26.7	27.7	30.3	-	24.7	25.6	28.1	-		
S/T	0.70	0.58	0.41	-	0.73	0.61	0.42	-	0.74	0.62	0.43	-	0.77	0.64	0.44	-	0.80	0.67	0.46	-	0.80	0.67	0.47	-		
ΔT	19	16	12	-	19	16	12	-	19	16	12	-	19	16	12	-	19	16	12	-	17	15	11	-		
kW	2.28	2.32	2.40	-	2.45	2.50	2.58	-	2.60	2.66	2.75	-	2.74	2.80	2.89	-	2.85	2.92	3.01	-	2.95	3.02	3.12	-		
Amps	10.1	10.3	10.6	-	10.8	11.0	11.3	-	11.5	11.8	12.1	-	12.2	12.5	12.8	-	12.9	13.2	13.5	-	13.5	13.8	14.2	-		
HI PR	232	250	264	-	261	280	296	-	296	319	337	-	338	363	384	-	380	409	432	-	420	452	477	-		
LO PR	107	114	124	-	113	120	131	-	117	125	136	-	123	131	143	-	129	137	150	-	134	142	155	-		

75	1350	MBh	34.3	35.3	38.2	41.0	33.5	34.5	37.3	40.0	32.7	33.7	36.4	39.1	31.9	32.8	35.5	38.1	30.3	31.2	33.8	36.2	28.1	28.9	31.3	33.6
		S/T	0.87	0.77	0.59	0.4	0.90	0.80	0.61	0.4	0.92	0.82	0.62	0.4	0.95	0.85	0.64	0.4	0.99	0.88	0.67	0.4	0.99	0.89	0.67	0.4
	ΔT	20	19	15	11	20	19	15	11	20	19	15	11	21	19	16	11	20	19	15	11	19	17	14	9.9	
	kW	2.37	2.42	2.50	2.6	2.55	2.61	2.69	2.8	2.71	2.77	2.86	3.0	2.86	2.92	3.01	3.1	2.98	3.04	3.14	3.3	3.08	3.15	3.26	3.4	
	Amps	10.5	10.7	11.0	11.3	11.2	11.4	11.7	12.1	12.0	12.2	12.6	13.0	12.7	13.0	13.4	13.8	13.4	13.7	14.1	14.6	14.1	14.4	14.8	15.4	
	HI PR	244	263	278	289.5	274	295	311	324.9	312	335	354	369.5	355	382	403	420.8	399	430	454	473.4	441	475	502	523.1	
	LO PR	112	120	131	139.0	119	126	138	146.9	123	131	143	152.7	130	138	151	160.4	136	145	158	168.1	141	150	163	173.8	
	MBh	33.3	34.3	37.1	39.8	32.5	33.5	36.2	38.9	31.7	32.7	35.4	38.0	31.0	<b>31.9</b>	34.5	37.0	29.4	30.3	32.8	35.2	27.2	28.1	30.4	32.6	
	S/T	0.83	0.74	0.56	0.4	0.86	0.77	0.58	0.4	0.88	0.78	0.59	0.4	0.91	<b>0.81</b>	0.61	0.4	0.94	0.84	0.64	0.4	0.95	0.85	0.64	0.4	
	ΔT	21	19	16	11	21	20	16	11	21	20	16	11	21	20	16	11	21	20	16	11	20	18	15	10.3	
kW	2.35	2.40	2.48	2.6	2.53	2.59	2.67	2.8	2.69	2.75	2.84	2.9	2.83	<b>2.89</b>	2.99	3.1	2.95	3.02	3.12	3.2	3.05	3.12	3.23	3.3		
Amps	10.4	10.6	10.9	11.2	11.1	11.3	11.6	12.0	11.9	12.2	12.5	12.9	12.6	<b>12.9</b>	13.2	13.7	13.3	13.6	14.0	14.5	14.0	14.3	14.7	15.2		
HI PR	242	260	275	286.7	271	292	308	321.7	309	332	351	365.8	352	<b>378</b>	399	416.7	396	426	449	468.8	437	470	497	517.9		
LO PR	111	118	129	137.7	118	125	137	145.4	122	130	142	151.2	128	<b>137</b>	149	158.8	135	143	156	166.4	139	148	162	172.1		
MBh	30.7	31.6	34.2	36.7	30.0	30.9	33.4	35.9	29.3	30.2	32.6	35.0	28.6	29.4	31.8	34.2	27.1	28.0	30.3	32.5	25.1	25.9	28.0	30.1		
S/T	0.80	0.71	0.54	0.3	0.83	0.74	0.56	0.4	0.85	0.76	0.57	0.4	0.87	0.78	0.59	0.4	0.91	0.81	0.61	0.4	0.91	0.82	0.62	0.4		
ΔT	21	20	16	11	22	20	16	11	22	20	16	11	22	20	16	11	22	20	16	11	20	19	15	10.5		
kW	2.29	2.34	2.42	2.5	2.47	2.52	2.60	2.7	2.62	2.68	2.77	2.9	2.76	2.82	2.91	3.0	2.88	2.94	3.04	3.1	2.98	3.04	3.15	3.3		
Amps	10.2	10.4	10.6	11.0	10.8	11.1	11.4	11.7	11.6	11.9	12.2	12.6	12.3	12.6	12.9	13.3	13.0	13.3	13.6	14.1	13.7	14.0	14.4	14.8		
HI PR	235	252	267	278.1	263	283	299	312.0	299	322	340	354.9	341	367	388	404.2	384	413	436	454.7	424	456	482	502.4		
LO PR	108	115	125	133.5	114	121	132	141.1	119	126	138	146.6	125	132	145	154.0	130	139	152	161.4	135	144	157	167.0		

IDB: Entering Indoor Dry Bulb Temperature  
 High & low pressures are measured at the liquid & suction access fittings.  
 Shaded area reflects ACCA (TVA) conditions  
 kW = Total system power  
 Amps = outdoor unit amps (comp. + fans)



IDB		OUTDOOR AMBIENT TEMPERATURE																								
		65°F				75°F				85°F				95°F				105°F				115°F				
		59	63	67	71	59	63	67	71	59	63	67	71	59	63	67	71	59	63	67	71	59	63	67	71	
70	1800	MBh	47.0	48.8	53.4	-	45.9	47.6	52.2	-	44.8	46.5	50.9	-	43.8	45.4	49.7	-	41.6	43.1	47.2	-	38.5	39.9	43.7	-
		S/T	0.76	0.63	0.44	-	0.79	0.66	0.45	-	0.81	0.67	0.47	-	0.83	0.70	0.48	-	0.86	0.72	0.50	-	0.87	0.73	0.50	-
		ΔT	18	16	12	-	18	16	12	-	18	16	12	-	19	16	12	-	18	16	12	-	17	15	11	-
		kW	3.22	3.29	3.40	-	3.47	3.55	3.66	-	3.69	3.77	3.90	-	3.89	3.97	4.10	-	4.05	4.14	4.28	-	4.19	4.29	4.43	-
		Amps	13.6	13.9	14.3	-	14.6	14.9	15.3	-	15.7	16.1	16.5	-	16.7	17.1	17.6	-	17.7	18.1	18.6	-	18.6	19.1	19.7	-
	1600	HI PR	250	269	284	-	280	301	318	-	318	343	362	-	363	390	412	-	408	439	464	-	451	485	512	-
		LO PR	111	118	129	-	117	124	136	-	122	129	141	-	128	136	148	-	134	142	155	-	138	147	161	-
		MBh	45.7	47.3	51.9	-	44.6	46.2	50.7	-	43.5	45.1	49.4	-	42.5	44.0	48.2	-	40.4	41.8	45.8	-	37.4	38.7	42.5	-
		S/T	0.72	0.60	0.42	-	0.75	0.63	0.43	-	0.77	0.64	0.44	-	0.79	0.66	0.46	-	0.82	0.69	0.48	-	0.83	0.69	0.48	-
		ΔT	19	16	12	-	19	17	13	-	19	17	13	-	19	17	13	-	19	17	13	-	18	15	12	-
1400	kW	3.20	3.26	3.37	-	3.44	3.52	3.63	-	3.66	3.74	3.86	-	3.85	3.94	4.07	-	4.02	4.11	4.24	-	4.16	4.25	4.40	-	
	Amps	13.5	13.8	14.2	-	14.5	14.8	15.2	-	15.6	15.9	16.4	-	16.6	16.9	17.4	-	17.5	17.9	18.5	-	18.5	18.9	19.5	-	
	HI PR	247	266	281	-	277	298	315	-	315	339	358	-	359	386	408	-	404	435	459	-	446	480	507	-	
	LO PR	106	113	123	-	116	123	135	-	120	128	140	-	126	135	147	-	132	141	154	-	137	146	159	-	
	MBh	42.1	43.7	47.9	-	41.2	42.7	46.8	-	40.2	41.7	45.6	-	39.2	40.6	44.5	-	37.2	38.6	42.3	-	34.5	35.8	39.2	-	

75	1800	MBh	47.8	49.2	53.3	57.2	46.7	48.1	52.1	55.9	45.6	47.0	50.8	54.6	44.5	45.8	49.6	53.2	42.3	43.5	47.1	50.6	39.2	40.3	43.6	46.8
		S/T	0.86	0.77	0.58	0.4	0.89	0.80	0.61	0.4	0.92	0.82	0.62	0.4	0.95	0.85	0.64	0.4	0.98	0.88	0.66	0.4	0.99	0.89	0.67	0.4
		ΔT	21	19	16	11	21	20	16	11	21	20	16	11	22	20	16	11	22	20	16	11	20	18	15	10.3
		kW	3.25	3.32	3.42	3.5	3.50	3.58	3.69	3.8	3.72	3.81	3.93	4.1	3.92	4.01	4.14	4.3	4.09	4.18	4.32	4.5	4.23	4.33	4.47	4.6
		Amps	13.7	14.0	14.4	14.9	14.7	15.0	15.5	16.0	15.9	16.2	16.7	17.3	16.8	17.2	17.7	18.4	17.8	18.2	18.8	19.5	18.8	19.2	19.8	20.5
	1600	HI PR	252	271	286	298.8	283	304	321	335.3	322	346	366	381.3	366	394	416	434.3	412	444	468	488.5	455	490	518	539.8
		LO PR	112	119	130	138.3	118	126	137	146.2	123	131	143	151.9	129	137	150	159.6	135	144	157	167.2	140	149	162	173.0
		MBh	46.4	47.8	51.8	55.5	45.4	46.7	50.6	54.3	44.3	45.6	49.3	53.0	43.2	44.5	48.1	51.7	41.0	42.3	45.7	49.1	38.0	39.1	42.4	45.5
		S/T	0.82	0.74	0.56	0.4	0.85	0.76	0.58	0.4	0.87	0.78	0.59	0.4	0.90	0.81	0.61	0.4	0.94	0.84	0.63	0.4	0.94	0.84	0.64	0.4
		ΔT	22	20	17	11	22	20	17	12	22	20	17	12	22	20	17	12	22	20	17	12	21	19	16	10.7
1400	kW	3.22	3.29	3.40	3.5	3.47	3.55	3.66	3.8	3.69	3.77	3.90	4.0	3.89	3.97	4.11	4.2	4.05	4.14	4.28	4.4	4.20	4.29	4.43	4.6	
	Amps	13.6	13.9	14.3	14.8	14.6	14.9	15.3	15.9	15.7	16.1	16.6	17.1	16.7	17.1	17.6	18.2	17.7	18.1	18.6	19.3	18.6	19.1	19.7	20.4	
	HI PR	250	269	284	295.8	280	301	318	331.9	319	343	362	377.5	363	390	412	430.0	408	439	464	483.7	451	485	512	534.4	
	LO PR	111	118	129	137.0	117	124	136	144.7	122	129	141	150.4	128	136	148	158.0	134	142	155	165.6	138	147	161	171.2	
	MBh	42.9	44.1	47.8	51.3	41.9	43.1	46.7	50.1	40.9	42.1	45.5	48.9	39.9	41.1	44.4	47.7	37.9	39.0	42.2	45.3	35.1	36.1	39.1	42.0	

IDB: Entering Indoor Dry Bulb Temperature  
 High & low pressures are measured at the liquid & suction access fittings.  
 Shaded area reflects ACCA (TVA) conditions  
 kW = Total system power  
 Amps = outdoor unit amps (comp. + fans)

IDB		OUTDOOR AMBIENT TEMPERATURE												1059F												1159F																					
		859F						759F						959F						1059F						1159F																					
		ENTERING INDOOR WET BULB TEMPERATURE																																													
AIRFLOW	59	63	67	71	59	63	67	71	59	63	67	71	59	63	67	71	59	63	67	71	59	63	67	71	59	63	67	71	59	63	67	71															
1800	MBh	48.7	49.7	53.1	56.8	47.6	48.6	51.9	55.5	46.4	47.4	50.7	54.2	45.3	46.3	49.4	52.9	43.0	44.0	47.0	50.2	39.9	40.7	43.5	46.5	43.0	44.0	47.0	50.2	39.9	40.7	43.5	46.5														
	S/T	0.95	0.89	0.72	0.5	1.00	0.92	0.75	0.6	1.00	0.94	0.77	0.6	1.00	1.00	0.79	0.6	1.00	1.00	0.82	0.6	1.00	1.00	0.83	0.6	1.00	1.00	0.82	0.6	1.00	1.00	0.83	0.6														
	ΔT	24	23	20	16	24	23	20	16	24	23	20	16	23	24	20	16	22	22	20	16	20	21	18	14.7	22	22	20	16	20	21	18	14.7														
	kW	3.27	3.34	3.45	3.6	3.53	3.61	3.72	3.8	3.75	3.84	3.96	4.1	3.95	4.04	4.17	4.3	4.12	4.21	4.35	4.5	4.27	4.36	4.51	4.7	4.12	4.21	4.35	4.5	4.27	4.36	4.51	4.7														
	Amps	13.8	14.1	14.5	15.0	14.8	15.2	15.6	16.1	16.0	16.3	16.8	17.4	17.0	17.4	17.9	18.5	18.0	18.4	19.0	19.6	19.0	19.4	20.0	20.7	18.0	18.4	19.0	19.6	19.0	19.4	20.0	20.7														
	HI PR	255	274	289	301.8	286	307	325	338.6	325	350	369	385.1	370	398	421	438.6	416	448	473	493.5	460	495	523	545.2	416	448	473	493.5	460	495	523	545.2														
	LO PR	113	120	131	139.7	119	127	139	147.6	124	132	144	153.4	130	139	151	161.2	137	145	159	168.9	141	150	164	174.7	137	145	159	168.9	141	150	164	174.7														
	80	MBh	47.3	48.3	51.6	55.2	46.2	47.2	50.4	53.9	45.1	46.1	49.2	52.6	44.0	44.9	48.0	51.3	41.8	42.7	45.6	48.7	38.7	39.5	42.2	45.2	41.8	42.7	45.6	48.7	38.7	39.5	42.2	45.2													
	S/T	0.90	0.85	0.69	0.5	0.93	0.88	0.71	0.5	0.96	0.90	0.73	0.5	0.99	0.93	0.76	0.5	0.99	0.96	0.78	0.6	1.00	0.97	0.79	0.6	1.00	0.96	0.78	0.6	1.00	0.97	0.79	0.6														
	ΔT	25	23	20	16	25	24	21	17	25	24	21	17	25	24	21	17	25	24	21	16	22	22	19	15.3	24	24	21	16	22	22	19	15.3														
kW	3.25	3.32	3.42	3.5	3.50	3.58	3.69	3.8	3.72	3.81	3.93	4.1	3.92	4.01	4.14	4.3	4.09	4.18	4.32	4.5	4.23	4.33	4.47	4.6	4.09	4.18	4.32	4.5	4.23	4.33	4.47	4.6															
Amps	13.7	14.0	14.4	14.9	14.7	15.0	15.5	16.0	15.9	16.2	16.7	17.3	16.8	17.2	17.7	18.4	17.8	18.2	18.8	19.5	18.8	19.2	19.8	20.5	17.8	18.2	18.8	19.5	18.8	19.2	19.8	20.5															
HI PR	252	271	286	298.8	283	304	321	335.3	322	346	366	381.3	366	394	416	434.3	412	444	468	488.6	455	490	518	539.8	412	444	468	488.6	455	490	518	539.8															
LO PR	112	119	130	138.3	118	126	137	146.2	123	131	143	151.9	129	137	150	159.6	135	144	157	167.2	140	149	162	173.0	135	144	157	167.2	140	149	162	173.0															
1400	MBh	43.6	44.6	47.6	50.9	42.6	43.5	46.5	49.7	41.6	42.5	45.4	48.5	40.6	41.5	44.3	47.4	38.6	39.4	42.1	45.0	35.7	36.5	39.0	41.7	38.6	39.4	42.1	45.0	35.7	36.5	39.0	41.7														
S/T	0.87	0.82	0.66	0.5	0.90	0.85	0.69	0.5	0.92	0.87	0.71	0.5	0.95	0.89	0.73	0.5	0.99	0.93	0.76	0.6	1.00	0.94	0.76	0.6	1.00	0.93	0.76	0.6	1.00	0.94	0.76	0.6															
ΔT	25	24	21	17	25	24	21	17	25	24	21	17	25	24	21	17	25	24	21	17	23	22	20	15.6	25	24	21	17	23	22	20	15.6															
kW	3.17	3.24	3.34	3.4	3.42	3.49	3.60	3.7	3.63	3.71	3.83	4.0	3.82	3.91	4.04	4.2	3.98	4.07	4.21	4.4	4.12	4.22	4.36	4.5	3.98	4.07	4.21	4.4	4.12	4.22	4.36	4.5															
Amps	13.4	13.7	14.1	14.5	14.3	14.7	15.1	15.6	15.5	15.8	16.3	16.8	16.4	16.8	17.3	17.9	17.4	17.8	18.3	19.0	18.3	18.7	19.3	20.0	17.4	17.8	18.3	19.0	18.3	18.7	19.3	20.0															
HI PR	245	263	278	289.8	274	295	312	325.2	312	336	355	369.9	355	383	404	421.3	400	430	454	473.9	442	475	502	523.6	400	430	454	473.9	442	475	502	523.6															
LO PR	108	115	126	134.2	115	122	133	141.8	119	127	138	147.4	125	133	145	154.8	131	140	152	162.2	136	144	158	167.8	131	140	152	162.2	136	144	158	167.8															
1800	MBh	49.5	50.5	52.9	56.4	48.4	49.3	51.7	55.1	47.2	48.1	50.4	53.8	46.1	47.0	49.2	52.5	43.8	44.6	46.7	49.9	40.5	41.3	43.3	46.2	43.8	44.6	46.7	49.9	40.5	41.3	43.3	46.2														
	S/T	0.99	0.96	0.86	0.7	1.00	0.99	0.89	0.7	1.00	1.00	0.92	0.7	1.00	1.00	0.95	0.8	1.00	1.00	0.98	0.8	1.00	1.00	0.99	0.8	1.00	1.00	0.98	0.8	1.00	1.00	0.99	0.8														
	ΔT	25	25	23	20	25	25	24	20	24	25	24	20	24	24	24	21	22	23	23	20	21	21	22	19.0	22	23	23	20	21	21	22	19.0														
	kW	3.30	3.37	3.48	3.6	3.56	3.64	3.75	3.9	3.79	3.87	4.00	4.1	3.99	4.07	4.21	4.4	4.16	4.25	4.39	4.5	4.30	4.40	4.55	4.7	4.16	4.25	4.39	4.5	4.30	4.40	4.55	4.7														
	Amps	13.9	14.2	14.7	15.1	14.9	15.3	15.7	16.3	16.1	16.5	17.0	17.6	17.1	17.5	18.0	18.7	18.1	18.5	19.1	19.8	19.1	19.6	20.2	20.9	18.1	18.5	19.1	19.8	19.1	19.6	20.2	20.9														
	HI PR	257	277	292	304.8	289	311	328	342.0	328	353	373	389.0	374	402	425	443.0	421	453	478	498.4	465	500	528	550.7	421	453	478	498.4	465	500	528	550.7														
	LO PR	114	121	133	141.1	121	128	140	149.1	125	133	146	155.0	132	140	153	162.8	138	147	160	170.6	143	152	166	176.5	138	147	160	170.6	143	152	166	176.5														
	85	MBh	48.1	49.0	51.3	54.8	47.0	47.9	50.1	53.5	45.9	46.7	49.0	52.2	44.7	45.6	47.8	51.0	42.5	43.3	45.4	48.4	39.4	40.1	42.0	44.8	42.5	43.3	45.4	48.4	39.4	40.1	42.0	44.8													
	S/T	0.95	0.91	0.82	0.7	0.98	0.95	0.85	0.7	1.00	0.97	0.88	0.7	1.00	1.00	0.90	0.7	1.00	1.00	0.94	0.8	1.00	1.00	0.95	0.8	1.00	1.00	0.94	0.8	1.00	1.00	0.95	0.8														
	ΔT	26	26	24	21	26	26	25	21	26	26	25	21	26	26	25	21	26	26	25	21	24	25	24	21	19.8	24	25	24	21	23	23	23	19.8													
kW	3.27	3.34	3.45	3.6	3.53	3.61	3.72	3.8	3.75	3.84	3.96	4.1	3.95	4.04	4.17	4.3	4.12	4.21	4.35	4.5	4.27	4.36	4.51	4.7	4.12	4.21	4.35	4.5	4.27	4.36	4.51	4.7															
Amps	13.8	14.1	14.5	15.0	14.8	15.2	15.6	16.1	16.0	16.3	16.8	17.4	17.0	17.4	17.9	18.5	18.0	18.4	19.0	19.6	19.0	19.4	20.0	20.7	18.0	18.4	19.0	19.6	19.0	19.4	20.0	20.7															
HI PR	255	274	289	301.8	286	307	325	338.6	325	350	369	385.1	370	398	421	438.6	416	448	473	493.5	460	495	523	545.2	416	448	473	493.5	460	495	523	545.2															
LO PR	113	120	131	139.7	119	127	139	147.6	124	132	144	153.4	130	139	151	161.2	137	145	159	168.9	141	150	164	174.7	137	145	159	168.9	141	150	164	174.7															
1400	MBh	44.4	45.2	47.4	50.6	43.4	44.2	46.3	49.4	42.3	43.1	45.2	48.2	41.3	42.1	44.1	47.0	39.2	40.0	41.9	44.7	36.3	37.0	38.8	41.4	39.2	40.0	41.9	44.7	36.3	37.0	38.8	41.4														
S/T	0.91	0.88	0.79	0.6	0.95	0.91	0.82	0.7	0.97	0.94	0.84	0.7	1.00	0.97	0.87	0.7	1.00	1.00	0.90	0.7	1.00	1.00	0.91	0.7	1.00	1.00	0.90	0.7	1.00	1.00	0.91	0.7															
ΔT	27	26	25	21	27	26	25	22	27	26	25	22	27	27	25	22	27	26	25	22	26	26	24	23	20.1	26	26	25	22	24	24	23	20.1														
kW	3.20	3.26	3.37	3.5	3.44	3.52	3.63	3.8	3.66	3.74	3.86	4.0	3.85	3.94	4.07	4.2	4.02	4.11	4.24	4.4	4.16	4.25	4.39	4.5	4.02	4.11	4.24	4.4	4.16	4.25	4.39	4.5															
Amps	13.5	13.8	14.2	14.7	14.5	14.8	15.2	15.7	15.6	15.9	16.4	17.0	16.6	16.9	17.4	18.0	17.5	17.9	18.5	19.1	18.5	18.9	19.5	20.2	17.5	17.9	18.5	19.1	18.5	18.9	19.5	20.2															
HI PR	247	266	281	292.7	277	298	315	328.5	315	339	358	373.6	359	386	408	425.5	404	435	459	478.7	446																										

IDB		OUTDOOR AMBIENT TEMPERATURE																								
		65°F				75°F				85°F				95°F				105°F				115°F				
		59	63	67	71	59	63	67	71	59	63	67	71	59	63	67	71	59	63	67	71	59	63	67	71	
70	2080	MBh	56.8	58.9	64.5	-	55.5	57.5	63.0	-	54.2	56.2	61.5	-	52.9	54.8	60.0	-	50.2	52.1	57.0	-	46.5	48.2	52.8	-
		S/T	0.73	0.61	0.42	-	0.76	0.63	0.44	-	0.78	0.65	0.45	-	0.80	0.67	0.46	-	0.83	0.69	0.48	-	0.84	0.70	0.49	-
	ΔT	18	16	12	-	19	16	12	-	19	16	12	-	19	16	12	-	18	16	12	-	17	15	11	-	
	kW	4.07	4.16	4.29	-	4.39	4.49	4.64	-	4.68	4.78	4.94	-	4.93	5.04	5.21	-	5.15	5.26	5.44	-	5.33	5.45	5.64	-	
	Amps	6.2	6.6	7.2	-	7.6	8.0	8.6	-	9.1	9.6	10.2	-	10.4	10.9	11.6	-	11.7	12.3	13.0	-	13.1	13.6	14.4	-	
	HI PR	258	277	293	-	289	311	329	-	329	354	374	-	375	403	426	-	421	453	479	-	466	501	529	-	
	LO PR	107	114	124	-	113	120	131	-	118	125	137	-	124	131	144	-	130	138	150	-	134	143	156	-	
	MBh	55.2	57.2	62.7	-	53.9	55.9	61.2	-	52.6	54.5	59.7	-	51.3	53.2	58.3	-	48.8	50.5	55.4	-	45.2	46.8	51.3	-	
	S/T	0.70	0.58	0.40	-	0.72	0.60	0.42	-	0.74	0.62	0.43	-	0.76	0.64	0.44	-	0.79	0.66	0.46	-	0.80	0.67	0.46	-	
	ΔT	19	17	13	-	19	17	13	-	19	17	13	-	19	17	13	-	19	17	13	-	18	16	12	-	
kW	4.04	4.12	4.26	-	4.36	4.45	4.60	-	4.64	4.74	4.90	-	4.89	5.00	5.17	-	5.10	5.22	5.40	-	5.28	5.41	5.59	-		
Amps	6.1	6.5	7.0	-	7.4	7.8	8.4	-	8.9	9.4	10.0	-	10.2	10.7	11.4	-	11.5	12.1	12.8	-	12.8	13.4	14.2	-		
HI PR	255	275	290	-	286	308	325	-	326	350	370	-	371	399	421	-	417	449	474	-	461	496	524	-		
LO PR	106	113	123	-	112	119	130	-	116	124	135	-	122	130	142	-	128	136	149	-	133	141	154	-		
MBh	50.9	52.8	57.8	-	49.7	51.6	56.5	-	48.6	50.3	55.1	-	47.4	49.1	53.8	-	45.0	46.7	51.1	-	41.7	43.2	47.3	-		
S/T	0.67	0.56	0.39	-	0.70	0.58	0.40	-	0.71	0.60	0.41	-	0.74	0.62	0.43	-	0.76	0.64	0.44	-	0.77	0.64	0.45	-		
ΔT	19	17	13	-	20	17	13	-	20	17	13	-	20	17	13	-	20	17	13	-	18	16	12	-		
kW	3.94	4.02	4.15	-	4.25	4.34	4.48	-	4.52	4.62	4.78	-	4.76	4.87	5.04	-	4.97	5.08	5.26	-	5.15	5.27	5.45	-		
Amps	5.7	6.0	6.6	-	6.9	7.3	7.9	-	8.4	8.9	9.5	-	9.7	10.2	10.8	-	10.9	11.5	12.2	-	12.2	12.8	13.5	-		
HI PR	247	266	281	-	278	299	316	-	316	340	359	-	360	387	409	-	405	435	460	-	447	481	508	-		
LO PR	103	109	120	-	109	116	126	-	113	120	131	-	119	126	138	-	124	132	144	-	129	137	149	-		

75	2080	MBh	57.8	59.5	64.4	69.1	56.5	58.1	62.9	67.5	55.1	56.7	61.4	65.9	53.8	55.4	59.9	64.3	51.1	52.6	56.9	61.1	47.3	48.7	52.7	56.6
		S/T	0.83	0.74	0.56	0.4	0.86	0.77	0.58	0.4	0.88	0.79	0.60	0.4	0.91	0.81	0.62	0.4	0.94	0.85	0.64	0.4	0.95	0.85	0.65	0.4
	ΔT	21	20	16	11	21	20	16	11	21	20	16	11	22	20	16	11	22	20	16	11	21	20	18	15	10.4
	kW	4.10	4.19	4.33	4.5	4.43	4.53	4.68	4.8	4.72	4.83	4.99	5.2	4.97	5.09	5.26	5.4	5.19	5.31	5.49	5.7	5.38	5.50	5.69	5.9	
	Amps	6.4	6.8	7.3	8.0	7.7	8.2	8.8	9.5	9.3	9.8	10.4	11.2	10.6	11.1	11.8	12.7	12.0	12.5	13.3	14.2	13.3	13.9	14.7	15.6	
	HI PR	260	280	296	308.5	292	314	332	346.2	332	357	378	393.7	378	407	430	448.4	426	458	484	504.5	470	506	534	557.4	
	LO PR	108	115	126	133.9	114	122	133	141.4	119	126	138	147.0	125	133	145	154.4	131	139	152	161.8	135	144	157	167.4	
	MBh	56.1	57.8	62.5	67.1	54.8	56.4	61.1	65.6	53.5	55.1	59.6	64.0	52.2	53.7	58.2	62.4	49.6	51.1	55.3	59.3	45.9	47.3	51.2	54.9	
	S/T	0.79	0.71	0.54	0.3	0.82	0.73	0.56	0.4	0.84	0.75	0.57	0.4	0.87	0.78	0.59	0.4	0.90	0.81	0.61	0.4	0.91	0.81	0.62	0.4	
	ΔT	22	20	17	11	22	21	17	12	22	21	17	12	23	21	17	12	23	20	17	12	22	21	19	16	10.8
kW	4.07	4.16	4.29	4.4	4.39	4.49	4.64	4.8	4.68	4.79	4.95	5.1	4.93	5.04	5.21	5.4	5.15	5.26	5.44	5.6	5.33	5.45	5.64	5.8		
Amps	6.3	6.6	7.2	7.8	7.6	8.0	8.6	9.3	9.1	9.6	10.2	11.0	10.4	10.9	11.6	12.5	11.8	12.3	13.0	13.9	13.1	13.6	14.4	15.4		
HI PR	258	277	293	305.5	289	311	329	342.8	329	354	374	389.8	375	403	426	444.0	421	454	479	499.5	466	501	529	551.9		
LO PR	107	114	124	132.5	113	120	131	140.0	118	125	137	145.5	124	131	144	152.9	130	138	150	160.2	134	143	156	165.7		
MBh	51.8	53.3	57.7	62.0	50.6	52.1	56.4	60.5	49.4	50.8	55.0	59.1	48.2	49.6	53.7	57.6	45.8	47.1	51.0	54.7	42.4	43.7	47.3	50.7		
S/T	0.76	0.68	0.52	0.3	0.79	0.71	0.54	0.3	0.81	0.73	0.55	0.4	0.84	0.75	0.57	0.4	0.87	0.78	0.59	0.4	0.88	0.78	0.59	0.4		
ΔT	22	21	17	12	23	21	17	12	23	21	17	12	23	21	17	12	23	21	17	12	23	21	19	16	11.0	
kW	3.97	4.06	4.19	4.3	4.28	4.38	4.52	4.7	4.56	4.66	4.82	5.0	4.81	4.91	5.08	5.3	5.01	5.13	5.30	5.5	5.19	5.31	5.49	5.7		
Amps	5.8	6.2	6.7	7.3	7.1	7.5	8.1	8.8	8.6	9.0	9.7	10.4	9.9	10.4	11.0	11.8	11.1	11.7	12.4	13.3	12.4	13.0	13.7	14.7		
HI PR	250	269	284	296.3	281	302	319	332.5	319	343	363	378.1	363	391	413	430.7	409	440	465	484.5	452	486	513	535.3		
LO PR	104	111	121	128.6	110	117	128	135.8	114	121	133	141.2	120	128	139	148.3	126	134	146	155.4	130	138	151	160.8		

IDB: Entering Indoor Dry Bulb Temperature  
 High & low pressures are measured at the liquid & suction access fittings.  
 Shaded area reflects ACCA (TVA) conditions  
 kW = Total system power  
 Amps = outdoor unit amps (comp. + fans)

IDB		OUTDOOR AMBIENT TEMPERATURE												ENTERING INDOOR WET BULB TEMPERATURE												
		65°F				75°F				85°F				95°F				105°F				115°F				
		59	63	67	71	59	63	67	71	59	63	67	71	59	63	67	71	59	63	67	71	59	63	67	71	
80	2080	MBh	58.8	60.1	64.2	68.7	57.5	58.7	62.7	67.1	56.1	57.3	61.2	65.5	54.7	55.9	59.7	63.9	52.0	53.1	56.8	60.7	48.2	49.2	52.6	56.2
		S/T	0.91	0.85	0.69	0.5	0.94	0.88	0.72	0.5	0.97	0.91	0.74	0.6	1.00	0.94	0.76	0.6	1.00	1.00	0.79	0.6	1.00	1.00	0.80	0.6
		ΔT	24	23	20	16	24	23	20	16	24	23	20	16	24	23	20	16	23	23	20	16	21	22	19	14.8
		kW	4.14	4.23	4.37	4.5	4.47	4.57	4.72	4.9	4.76	4.87	5.03	5.2	5.02	5.13	5.31	5.5	5.24	5.36	5.54	5.7	5.42	5.55	5.74	5.9
		Amps	6.5	6.9	7.5	8.2	7.9	8.3	8.9	9.7	9.5	9.9	10.6	11.4	10.8	11.3	12.0	12.9	12.2	12.7	13.5	14.4	13.5	14.1	14.9	15.9
		HI PR	263	283	299	311.6	295	318	335	349.7	336	361	381	397.7	382	411	434	453.0	430	463	489	509.6	475	511	540	563.0
		LO PR	109	116	127	135.2	116	123	134	142.9	120	128	139	148.5	126	134	146	156.0	132	141	153	163.5	137	145	159	169.1
		MBh	57.1	58.4	62.4	66.7	55.8	57.0	60.9	65.1	54.5	55.6	59.5	63.6	53.1	54.3	58.0	62.0	50.5	51.6	55.1	58.9	46.8	47.8	51.0	54.6
		S/T	0.87	0.81	0.66	0.5	0.90	0.84	0.69	0.5	0.92	0.87	0.70	0.5	0.95	0.89	0.73	0.5	0.99	0.93	0.75	0.6	1.00	0.93	0.76	0.6
		ΔT	25	24	21	16	25	24	21	17	25	24	21	17	25	24	21	17	25	24	21	17	23	22	19	15.4
	kW	4.10	4.19	4.33	4.5	4.43	4.53	4.68	4.8	4.72	4.83	4.99	5.2	4.97	5.09	5.26	5.4	5.19	5.31	5.49	5.7	5.38	5.50	5.69	5.9	
	Amps	6.4	6.8	7.3	8.0	7.7	8.2	8.8	9.5	9.3	9.8	10.4	11.2	10.6	11.1	11.8	12.7	12.0	12.5	13.3	14.2	13.3	13.9	14.7	15.6	
	HI PR	260	280	296	308.6	292	314	332	346.2	332	358	378	393.8	378	407	430	448.5	426	458	484	504.6	470	506	534	557.5	
	LO PR	108	115	126	133.9	114	122	133	141.5	119	126	138	147.0	125	133	145	154.4	131	139	152	161.8	135	144	157	167.4	
	MBh	52.7	53.9	57.5	61.5	51.5	52.6	56.2	60.1	50.3	51.4	54.9	58.7	49.0	50.1	53.5	57.2	46.6	47.6	50.9	54.4	43.2	44.1	47.1	50.4	
	S/T	0.84	0.79	0.64	0.5	0.87	0.81	0.66	0.5	0.89	0.83	0.68	0.5	0.92	0.86	0.70	0.5	0.95	0.89	0.73	0.5	0.96	0.90	0.73	0.5	
	ΔT	25	24	21	17	25	24	21	17	25	24	21	17	26	24	21	17	25	24	21	17	24	23	20	15.7	
	kW	4.00	4.09	4.22	4.4	4.32	4.42	4.56	4.7	4.60	4.70	4.86	5.0	4.85	4.96	5.12	5.3	5.06	5.17	5.35	5.5	5.24	5.36	5.54	5.7	
	Amps	6.0	6.3	6.9	7.5	7.3	7.7	8.3	8.9	8.8	9.2	9.9	10.6	10.0	10.5	11.2	12.0	11.3	11.9	12.6	13.5	12.6	13.2	14.0	14.9	
	HI PR	253	272	287	299.3	283	305	322	335.8	322	347	366	382.0	367	395	417	435.0	413	444	469	489.4	456	491	518	540.7	
	LO PR	105	112	122	129.9	111	118	129	137.2	115	123	134	142.6	121	129	141	149.8	127	135	147	157.0	131	140	152	162.4	
	MBh	59.9	61.0	63.9	68.2	58.5	59.6	62.4	66.6	57.1	58.2	60.9	65.0	55.7	56.8	59.4	63.4	52.9	53.9	56.5	60.2	49.0	49.9	52.3	55.8	
	S/T	0.95	0.92	0.83	0.7	0.99	0.95	0.86	0.7	1.00	0.98	0.88	0.7	1.00	0.96	0.87	0.7	1.00	1.00	0.95	0.8	1.00	1.00	0.95	0.8	
	ΔT	25	25	23	20	26	25	24	21	25	25	24	21	25	25	24	21	23	24	24	20	22	22	22	19.1	
	kW	4.17	4.26	4.40	4.6	4.51	4.61	4.76	4.9	4.80	4.91	5.07	5.2	5.06	5.18	5.35	5.5	5.28	5.40	5.59	5.8	5.47	5.60	5.79	6.0	
	Amps	6.7	7.1	7.7	8.3	8.1	8.5	9.1	9.8	9.6	10.1	10.8	11.6	11.0	11.5	12.2	13.1	12.4	12.9	13.7	14.6	13.7	14.3	15.1	16.1	
	HI PR	266	286	302	314.8	298	321	339	353.2	339	365	385	401.7	386	415	439	457.5	434	467	493	514.7	480	516	545	568.7	
	LO PR	110	117	128	136.6	117	124	135	144.3	121	129	141	150.0	127	135	148	157.5	133	142	155	165.1	138	147	160	170.8	
	MBh	58.1	59.2	62.0	66.2	56.8	57.9	60.6	64.6	55.4	56.5	59.2	63.1	54.1	55.1	57.7	61.6	51.4	52.3	54.8	58.5	47.6	48.5	50.8	54.2	
	S/T	0.91	0.88	0.79	0.6	0.94	0.91	0.82	0.7	0.97	0.93	0.84	0.7	1.00	0.96	0.87	0.7	1.00	1.00	0.90	0.7	1.00	1.00	0.91	0.7	
	ΔT	26	26	24	21	27	26	25	21	27	26	25	21	27	26	25	22	26	26	25	21	24	24	23	19.9	
	kW	4.14	4.23	4.37	4.5	4.47	4.57	4.72	4.9	4.76	4.87	5.03	5.2	5.02	5.13	5.31	5.5	5.24	5.36	5.54	5.7	5.42	5.55	5.74	5.9	
	Amps	6.5	6.9	7.5	8.2	7.9	8.3	8.9	9.7	9.5	9.9	10.6	11.4	10.8	11.3	12.0	12.9	12.2	12.7	13.5	14.4	13.5	14.1	14.9	15.9	
	HI PR	263	283	299	311.6	295	318	335	349.7	336	361	381	397.7	382	411	434	453.0	430	463	489	509.6	475	511	540	563.0	
	LO PR	109	116	127	135.2	116	123	134	142.9	120	128	139	148.5	126	134	146	156.0	132	141	153	163.5	137	145	159	169.1	
	MBh	53.6	54.7	57.3	61.1	52.4	53.4	55.9	59.7	51.1	52.1	54.6	58.2	49.9	50.9	53.3	56.8	47.4	48.3	50.6	54.0	43.9	44.8	46.9	50.0	
	S/T	0.88	0.85	0.76	0.6	0.91	0.88	0.79	0.6	0.93	0.90	0.81	0.7	0.96	0.93	0.84	0.7	1.00	0.96	0.87	0.7	1.00	0.97	0.88	0.7	
	ΔT	27	26	25	21	27	27	25	22	27	27	25	22	27	27	25	22	27	26	25	22	25	25	23	20.2	
	kW	4.04	4.12	4.26	4.4	4.36	4.45	4.60	4.8	4.64	4.74	4.90	5.1	4.89	5.00	5.17	5.3	5.10	5.22	5.39	5.6	5.28	5.41	5.59	5.8	
	Amps	6.1	6.5	7.0	7.7	7.4	7.8	8.4	9.1	8.9	9.4	10.0	10.8	10.2	10.7	11.4	12.2	11.5	12.1	12.8	13.7	12.8	13.4	14.2	15.1	
	HI PR	255	274	290	302.3	286	308	325	339.2	325	350	370	385.8	371	399	421	439.4	417	449	474	494.3	461	496	524	546.2	
	LO PR	106	113	123	131.2	112	119	130	138.6	116	124	135	144.0	122	130	142	151.3	128	136	149	158.6	133	141	154	164.0	

IDB: Entering Indoor Dry Bulb Temperature  
 High & low pressures are measured at the liquid & suction access fittings.  
 Shaded area reflects AHRH (TVA) conditions  
 kW = Total system power  
 Amps = outdoor unit amps (comp. + fans)

**APH1424M41A\***

	OUTDOOR AMBIENT TEMPERATURE																	
	65	60	55	50	47	45	40	35	30	25	20	17	15	10	5	0	-5	-10
MBh	28.9	27.4	25.8	24.1	23.0	22.3	20.7	19.1	15.7	14.5	13.3	12.6	12.1	10.9	9.7	8.4	7.2	5.9
T/R	31.5	29.8	28.1	26.2	25.1	24.3	22.5	20.8	17.1	15.8	14.5	13.7	13.2	11.9	10.5	9.2	7.8	6.4
kW	1.90	1.87	1.83	1.79	1.77	1.75	1.72	1.68	1.70	1.66	1.62	1.60	1.58	1.55	1.51	1.47	1.43	1.39
Amps	10.1	9.4	8.9	8.5	8.2	8.1	7.7	7.4	7.1	6.9	6.6	6.5	6.4	6.1	5.8	5.6	5.2	4.8
COP	4.45	4.29	4.12	3.93	3.80	3.72	3.53	3.32	2.70	2.55	2.41	2.30	2.24	2.06	1.87	1.68	1.47	1.24
HI PR	377	361	347	332	324	318	306	293	281	269	258	252	247	238	229	219	211	204
LO PR	139	129	121	111	105	101	92	82	74	66	58	54	52	44	38	32	28	22

**APH1430M41A\***

	OUTDOOR AMBIENT TEMPERATURE																	
	65	60	55	50	47	45	40	35	30	25	20	17	15	10	5	0	-5	-10
MBh	35.2	33.3	31.4	29.3	28.0	27.1	25.2	23.2	18.7	17.3	15.9	15.0	14.4	13.0	11.5	10.0	8.6	7.0
T/R	31.0	29.4	27.7	25.9	24.7	23.9	22.2	20.5	16.5	15.2	14.0	13.2	12.7	11.4	10.1	8.8	7.5	6.2
kW	2.36	2.31	2.26	2.21	2.19	2.17	2.12	2.07	2.05	2.00	1.95	1.93	1.91	1.86	1.81	1.77	1.72	1.67
Amps	5.6	5.4	5.1	4.9	4.8	4.8	4.6	4.5	4.3	4.2	4.1	4.1	4.0	3.9	3.8	3.7	3.5	3.4
COP	4.37	4.22	4.06	3.87	3.75	3.66	3.48	3.28	2.67	2.52	2.38	2.28	2.22	2.04	1.86	1.66	1.46	1.23
HI PR	385	370	355	340	332	325	313	300	288	275	264	257	253	243	234	224	216	209
LO PR	138	128	120	110	104	100	92	82	74	66	58	54	52	44	38	32	28	22

**APH1436M41A\***

	OUTDOOR AMBIENT TEMPERATURE																	
	65	60	55	50	47	45	40	35	30	25	20	17	15	10	5	0	-5	-10
MBh	41.7	39.5	37.2	34.8	33.2	32.2	29.9	27.6	23.7	21.9	20.1	19.0	18.3	16.4	14.6	12.7	10.8	8.9
T/R	32.2	30.5	28.7	26.8	25.6	24.8	23.1	21.3	18.3	16.9	15.5	14.7	14.1	12.7	11.2	9.8	8.4	6.8
kW	2.76	2.71	2.66	2.60	2.57	2.55	2.49	2.44	2.53	2.47	2.41	2.38	2.36	2.30	2.24	2.18	2.13	2.07
Amps	7.0	6.6	6.4	6.1	6.0	5.9	5.7	5.5	5.4	5.2	5.1	5.0	5.0	4.9	4.7	4.5	4.4	4.2
COP	4.42	4.27	4.10	3.91	3.78	3.70	3.51	3.30	2.74	2.59	2.44	2.34	2.27	2.09	1.90	1.70	1.49	1.26
HI PR	391	375	361	345	337	330	318	305	292	279	268	261	257	247	237	228	220	212
LO PR	134	125	117	107	101	97	90	80	72	64	57	53	51	43	37	31	27	21

**Notes**  
 Above information is for nominal CFM and 70-degree indoor dry bulb. Instantaneous capacity listed.  
 High pressure is measured at the liquid line access fitting. Amps: Unit amps (comp.+ evaporator motor + condenser fan motor)  
 Low pressure is measured at the compressor suction access fitting. kW = Total system power



## APH1442M41A\*

	OUTDOOR AMBIENT TEMPERATURE																	
	65	60	55	50	47	45	40	35	30	25	20	17	15	10	5	0	-5	-10
MBh	50.9	48.2	45.4	42.4	40.5	39.2	36.5	33.6	28.0	25.9	23.8	22.5	21.7	19.4	17.2	15.0	12.8	10.5
T/R	36.3	34.3	32.3	30.2	28.8	28.0	26.0	23.9	20.0	18.4	17.0	16.0	15.4	13.8	12.3	10.7	9.1	7.5
kW	3.49	3.42	3.35	3.28	3.24	3.21	3.15	3.08	3.00	2.93	2.86	2.82	2.79	2.72	2.65	2.58	2.51	2.45
Amps	18.9	17.7	16.7	15.8	15.3	15.0	14.3	13.7	13.2	12.7	12.2	11.9	11.8	11.3	10.6	10.1	9.5	8.8
COP	4.26	4.12	3.96	3.78	3.65	3.57	3.39	3.20	2.74	2.59	2.44	2.34	2.27	2.09	1.90	1.70	1.49	1.26
HI PR	406	389	374	358	349	343	329	316	303	289	278	271	266	256	246	236	228	220
LO PR	134	124	117	107	101	97	89	80	72	64	56	52	51	43	37	31	27	21

## APH1448M41A\*

	OUTDOOR AMBIENT TEMPERATURE																	
	65	60	55	50	47	45	40	35	30	25	20	17	15	10	5	0	-5	-10
MBh	57.3	54.3	51.1	47.7	45.6	44.2	41.0	37.8	33.0	30.5	28.1	26.5	25.5	22.9	20.3	17.7	15.1	12.4
T/R	33.2	31.4	29.6	27.6	26.4	25.6	23.8	21.9	19.1	17.6	16.2	15.3	14.8	13.3	11.7	10.2	8.7	7.2
kW	3.87	3.79	3.71	3.64	3.59	3.56	3.49	3.41	3.41	3.33	3.25	3.21	3.18	3.10	3.02	2.94	2.86	2.79
Amps	19.0	17.7	16.7	15.8	15.3	15.0	14.2	13.6	13.1	12.5	12.0	11.8	11.6	11.1	10.5	10.0	9.3	8.5
COP	4.34	4.19	4.02	3.84	3.71	3.63	3.44	3.25	2.84	2.68	2.53	2.42	2.35	2.16	1.97	1.76	1.54	1.30
HI PR	387	371	356	341	333	326	314	301	289	276	265	258	254	244	235	225	217	209
LO PR	129	120	112	103	97	93	86	77	69	62	54	50	49	41	35	30	26	21

## APH1460M41A\*

	OUTDOOR AMBIENT TEMPERATURE																	
	65	60	55	50	47	45	40	35	30	25	20	17	15	10	5	0	-5	-10
MBh	71.6	67.8	63.8	59.7	57.0	55.2	51.3	47.3	39.1	36.1	33.3	31.4	30.2	27.1	24.1	21.0	17.9	14.7
T/R	35.9	33.9	32.0	29.9	28.5	27.6	25.7	23.7	19.6	18.1	16.6	15.7	15.1	13.6	12.0	10.5	9.0	7.3
kW	5.06	4.96	4.85	4.75	4.69	4.65	4.55	4.44	4.10	4.00	3.91	3.85	3.81	3.72	3.62	3.53	3.43	3.34
Amps	30.1	27.1	24.6	22.5	21.2	20.6	18.8	17.3	16.0	14.8	13.6	13.0	12.7	11.4	9.9	8.7	7.2	5.3
COP	4.15	4.01	3.85	3.68	3.56	3.48	3.30	3.12	2.79	2.64	2.49	2.39	2.32	2.14	1.94	1.74	1.53	1.29
HI PR	426	409	393	376	367	360	346	332	318	304	292	285	280	269	259	248	239	231
LO PR	126	117	110	101	95	92	84	75	68	61	53	49	48	40	35	29	26	20

**Notes**

Above information is for nominal CFM and 70-degree indoor dry bulb. Instantaneous capacity listed.

High pressure is measured at the liquid line access fitting.

Amps: Unit amps (comp.+ evaporator motor + condenser fan motor)

Low pressure is measured at the compressor suction access fitting.

kW = Total system power

APH1424M41\*

POSITION	MOTOR SPEED	VOLTS		STATIC								
				0.1	0.2	0.3	0.4	0.5	0.6	0.7	0.8	0.9
Horizontal Position	T1	230	CFM	782	709	652	561	---	---	---	---	---
			Watts	71	78	86	100	---	---	---	---	---
	T2/T3	230	CFM	941	872	777	746	614	---	---	---	---
			Watts	105	112	113	128	138	---	---	---	---
	T4/T5	230	CFM	1347	1315	1256	1194	1152	1096	1051	972	891
			Watts	239	256	265	271	282	286	293	297	305
Downshot Position	T1	230	CFM	790	710	634	566	506	---	---	---	---
			Watts	82	86	96	103	108	---	---	---	---
	T2/T3	230	CFM	919	855	782	695	631	578	523	---	---
			Watts	108	117	121	132	143	144	149	---	---
	T4/T5	230	CFM	1312	1275	1216	1153	1096	1028	943	869	816
			Watts	260	269	274	285	295	300	304	310	316

APH1430M41\*

POSITION	MOTOR SPEED	VOLTS		STATIC								
				0.1	0.2	0.3	0.4	0.5	0.6	0.7	0.8	0.9
Horizontal Position	T1	230	CFM	851	803	712	635	575	506	460	---	---
			Watts	79	88	91	100	114	116	120	---	---
	T2/T3	230	CFM	1146	1098	1044	991	934	817	764	698	653
			Watts	157	170	176	186	194	201	210	215	215
	T4/T5	230	CFM	1440	1418	1364	1307	1265	1219	1168	1094	1049
			Watts	290	306	312	321	326	332	348	353	360
Downshot Position	T1	230	CFM	848	761	646	578	511	---	---	---	---
			Watts	84	94	98	111	113	---	---	---	---
	T2/T3	230	CFM	1103	1038	978	922	806	731	676	622	564
			Watts	162	168	179	188	199	205	208	214	219
	T4/T5	230	CFM	1401	1357	1305	1244	1179	1118	1046	934	884
			Watts	311	326	318	334	341	349	353	352	357

APH1436M41\*

POSITION	MOTOR SPEED	VOLTS		STATIC								
				0.1	0.2	0.3	0.4	0.5	0.6	0.7	0.8	0.9
Horizontal Position	T1	230	CFM	846	762	716	585	519	---	---	---	---
			Watts	74	83	94	98	108	---	---	---	---
	T2/T3	230	CFM	1278	1214	1182	1129	1072	1013	950	853	788
			Watts	221	218	232	245	253	264	265	275	272
	T4/T5	230	CFM	1604	1560	1507	1468	1415	1364	1321	1276	1218
			Watts	396	402	408	424	426	423	444	454	454
Downshot Position	T1	230	CFM	809	730	623	542	485	441	---	---	---
			Watts	73	85	92	98	107	112	---	---	---
	T2/T3	230	CFM	1284	1223	1175	1097	1031	974	871	804	761
			Watts	220	227	241	247	255	262	272	277	285
	T4/T5	230	CFM	1578	1539	1498	1452	1396	1332	1279	1224	1161
			Watts	401	409	421	425	438	439	452	453	455

## APH1442M41\*

POSITION	MOTOR SPEED	VOLTS		STATIC								
				0.1	0.2	0.3	0.4	0.5	0.6	0.7	0.8	0.9
Horizontal Position	T1	230	CFM	1030	955	908	826	761	678	633	563	504
			Watts	130	126	139	143	154	168	171	181	185
	T2/T3	230	CFM	1419	1387	1327	1274	1219	1171	1111	1041	986
			Watts	273	281	287	298	309	315	318	326	336
	T4/T5	230	CFM	1750	1710	1673	1611	1556	1499	1443	1399	1353
			Watts	470	475	488	493	502	502	501	514	520
Downshot Position	T1	230	CFM	1001	936	852	810	700	643	579	526	491
			Watts	125	133	136	154	160	166	172	177	185
	T2/T3	230	CFM	1411	1361	1299	1240	1173	1112	1048	955	887
			Watts	281	294	301	309	312	320	327	335	339
	T4/T5	230	CFM	1734	1678	1613	1558	1509	1449	1383	1341	1279
			Watts	475	485	496	504	509	505	519	514	520

## APH1448M41\*

POSITION	MOTOR SPEED	VOLTS		STATIC								
				0.1	0.2	0.3	0.4	0.5	0.6	0.7	0.8	0.9
Horizontal Position	T1	230	CFM	1167	1101	1045	992	939	870	802	732	681
			Watts	139	144	156	165	177	193	203	217	223
	T2/T3	230	CFM	1723	1637	1598	1554	1509	1467	1420	1361	1295
			Watts	372	370	381	390	404	411	420	427	441
	T4/T5	230	CFM	2012	1965	1912	1871	1809	1770	1741	1691	1635
			Watts	578	593	599	606	610	627	626	634	638
Downshot Position	T1	230	CFM	1155	1074	1023	969	896	805	755	667	626
			Watts	153	156	169	180	195	205	216	226	230
	T2/T3	230	CFM	1670	1596	1558	1484	1467	1383	1339	1259	1168
			Watts	383	392	399	408	419	434	436	447	449
	T4/T5	230	CFM	1949	1881	1853	1792	1753	1699	1621	1561	1522
			Watts	603	607	608	616	622	626	648	650	645

## APH1460M41\*

POSITION	MOTOR SPEED	VOLTS		STATIC								
				0.1	0.2	0.3	0.4	0.5	0.6	0.7	0.8	0.9
Horizontal Position	T1	230	CFM	1427	1370	1317	1273	1204	1165	1111	1058	1003
			Watts	222	229	237	256	256	276	291	299	320
	T2/T3	230	CFM	1935	1885	1848	1809	1755	1705	1659	1616	1567
			Watts	498	512	515	520	541	549	559	567	569
	T4/T5	230	CFM	2232	2188	2144	2087	2035	2017	1963	1926	1869
			Watts	805	795	790	827	830	842	864	864	848
Downshot Position	T1	230	CFM	1347	1293	1236	1184	1117	1054	996	934	871
			Watts	242	251	268	276	290	305	321	330	348
	T2/T3	230	CFM	1827	1780	1739	1683	1633	1588	1518	1462	1404
			Watts	529	538	548	557	557	576	578	604	601
	T4/T5	230	CFM	2111	2057	2030	1979	1947	1957	1922	1868	1818
			Watts	835	843	846	852	870	959	956	960	966

**HEAT KIT ELECTRICAL DATA (BLOWER ONLY, HEAT MODE)**

MODEL AND HEAT KIT USAGE	CIRCUIT #1		CIRCUIT #2		SINGLE-POINT KIT		ACTUAL KW / BTU@ 240V
	MCA <sup>1</sup>	MOP <sup>2</sup>	MCA <sup>1</sup>	MOP <sup>2</sup>	MCA <sup>1</sup>	MOP <sup>2</sup>	
<b>APH1424M41**</b>	4.3	---	---	---	--	--	---
HKP-05C*	21 / 25	25 / 25	---	---	47	50	4.75 / 16,200
HKR-08C*	32 / 36	35 / 40	---	---	58	60	7.0 / 23,800
HKP-10C*	43 / 49	45 / 50	---	---	71	80	9.5 / 32,400
<b>APH1430M41**</b>	4.3	---	---	---	--	--	---
HKP-05C*	21 / 25	25 / 25	---	---	48	50	4.75 / 16,200
HKR-08C*	32 / 36	35 / 40	---	---	60	60	7.0 / 23,800
HKP-10C*	43 / 49	45 / 50	---	---	73	80	9.5 / 32,400
HKP-15C*	43 / 49	45 / 50	21 / 25	25 / 25	98	110	14.25 / 48,600
<b>APH1436M41**</b>	4.3	---	---	---	--	--	---
HKP-05C*	21 / 25	25 / 25	---	---	51	60	4.75 / 16,200
HKR-08C*	32 / 36	35 / 40	---	---	63	70	7.0 / 23,800
HKP-10C*	43 / 49	45 / 50	---	---	76	80	9.5 / 32,400
HKP-15C*	43 / 49	45 / 50	21 / 25	25 / 25	101	110	14.25 / 48,600
<b>APH1442M41**</b>	5.8	---	---	---	--	--	---
HKP-05C*	21 / 25	25 / 25	---	---	54	60	4.75 / 16,200
HKR-08C*	32 / 36	35 / 40	---	---	66	70	7.0 / 23,800
HKP-10C*	43 / 49	45 / 50	---	---	79	80	9.5 / 32,400
HKP-15C*	43 / 49	45 / 50	21 / 25	25 / 25	104	110	14.25 / 48,600
<b>APH1448M41**</b>	5.8	---	---	---	--	--	---
HKP-05C*	21 / 25	25 / 25	---	---	59	70	4.75 / 16,200
HKR-08C*	32 / 36	35 / 40	---	---	71	80	7.0 / 23,800
HKP-10C*	43 / 49	45 / 50	---	---	84	90	9.5 / 32,400
HKP-15C*	43 / 49	45 / 50	21 / 25	25 / 25	109	110	14.25 / 48,600
HKP-20C	43 / 49	45 / 50	43 / 49	45 / 50	133	150	19.0 / 64,800
<b>APH1460M41**</b>	7.6	---	---	---	--	--	---
HKP-05C*	21 / 25	25 / 25	---	---	69	90	4.75 / 16,200
HKR-08C*	32 / 36	35 / 40	---	---	80	100	7.0 / 23,800
HKP-10C*	43 / 49	45 / 50	---	---	94	110	9.5 / 32,400
HKP-15C*	43 / 49	45 / 50	21 / 25	25 / 25	118	125	14.25 / 48,600
HKP-20C	43 / 49	45 / 50	43 / 49	45 / 50	142	150	19.0 / 64,800

<sup>1</sup> Minimum Circuit Ampacity @ 208 / 240 V

<sup>2</sup> Maximum Overcurrent Protection Device @ 208 / 240 V

\* Revision level that may or may not be designated

C Circuit breaker option

**NOTE:** HKP-15C\* and HKP-20C\* replace HKR-15C and HKR-20C respectively to meet new UL1995 requirements.

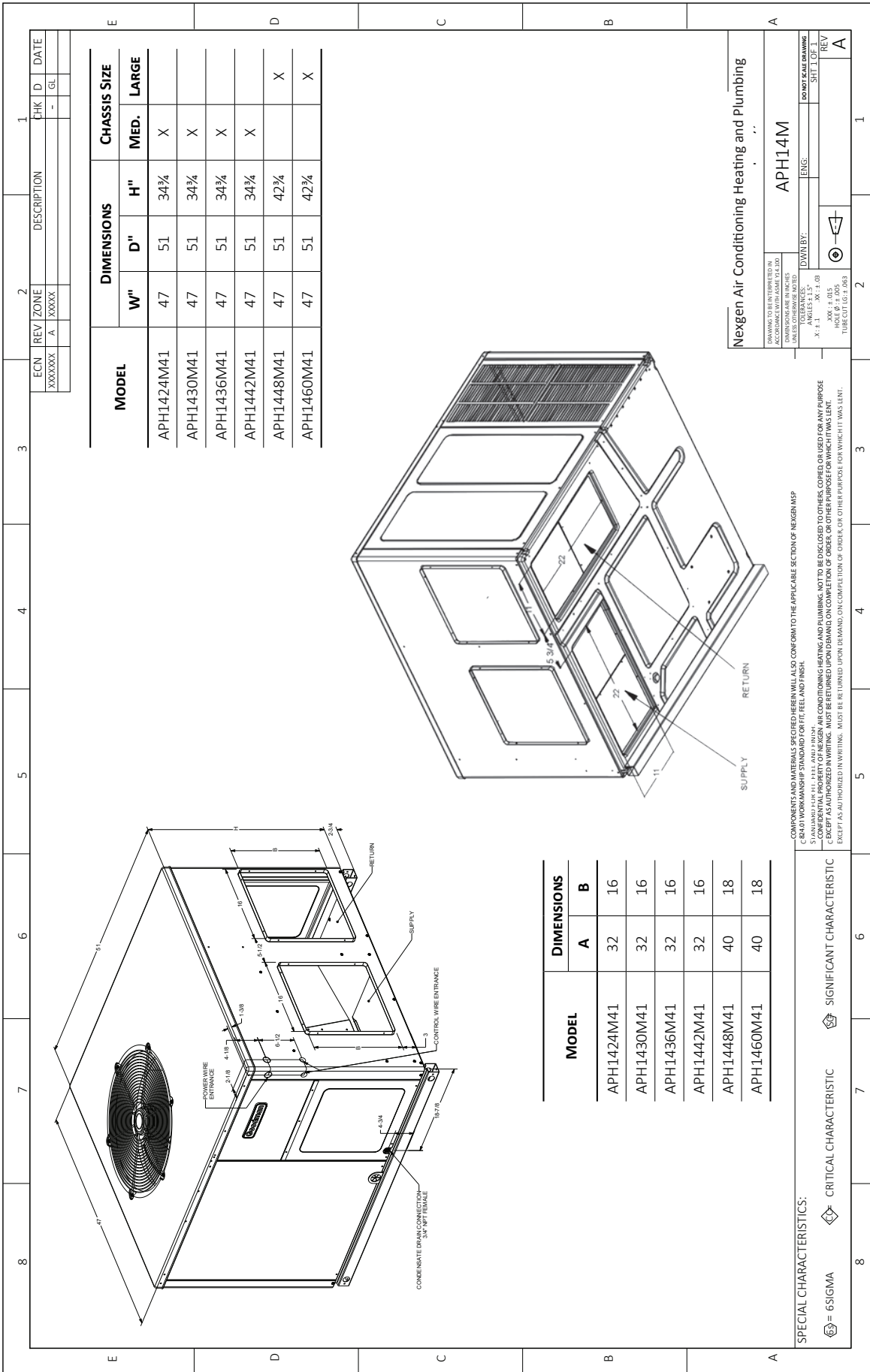

MODEL	DIMENSIONS	
	A	B
APH1424M41	32	16
APH1430M41	32	16
APH1436M41	32	16
APH1442M41	32	16
APH1448M41	40	18
APH1460M41	40	18

SPECIAL CHARACTERISTICS:  
 6SIGMA = 6SIGMA  
 6CRITICAL CHARACTERISTIC  
 6SIGNIFICANT CHARACTERISTIC

COMPONENTS AND MATERIALS SPECIFIED HEREIN WILL ALSO CONFORM TO THE APPLICABLE SECTION OF NEXGEN MSP C-3600 WORKMANSHIP STANDARDS FOR FIT, FIELD AND FINISH.  
 NEXGEN AIR CONDITIONING HEATING AND PLUMBING IS THE CONFIDENTIAL PROPERTY OF NEXGEN. NOT TO BE DISCLOSED TO OTHERS, COPIED OR USED FOR ANY PURPOSE EXCEPT AS AUTHORIZED IN WRITING. MUST BE RETURNED UPON DEMAND ON COMPLETION OF ORDER OR OTHER PURPOSE FOR WHICH IT WAS LENT.  
 EXCEPT AS AUTHORIZED IN WRITING, MUST BE RETURNED UPON DEMAND ON COMPLETION OF ORDER OR OTHER PURPOSE FOR WHICH IT WAS LENT.

**Nexgen Air Conditioning Heating and Plumbing**

MODEL: APH1414M

DRAWING TO BE INTERFERED ON: \_\_\_\_\_  
 DRAWING TO BE USED: \_\_\_\_\_  
 DIMENSIONS TO BE USED: \_\_\_\_\_  
 UNLESS OTHERWISE NOTED.

DWYN BY: \_\_\_\_\_  
 ENGR: \_\_\_\_\_  
 JAMES L. ST. \_\_\_\_\_

X: 1.1    XX: 1.0B  
 Y: 1.1    YY: 1.0B  
 Z: 1.1    ZZ: 1.0B

TUBE CUT 16.1.063

1 2 3 4 5 6 7 8

ECN	REV	ZONE	DESCRIPTION	CHK	D	DATE
XXXXXX	A	XXXXX		-	GL	



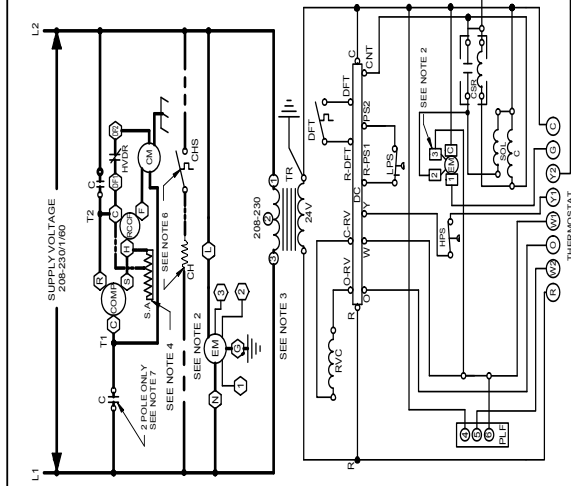
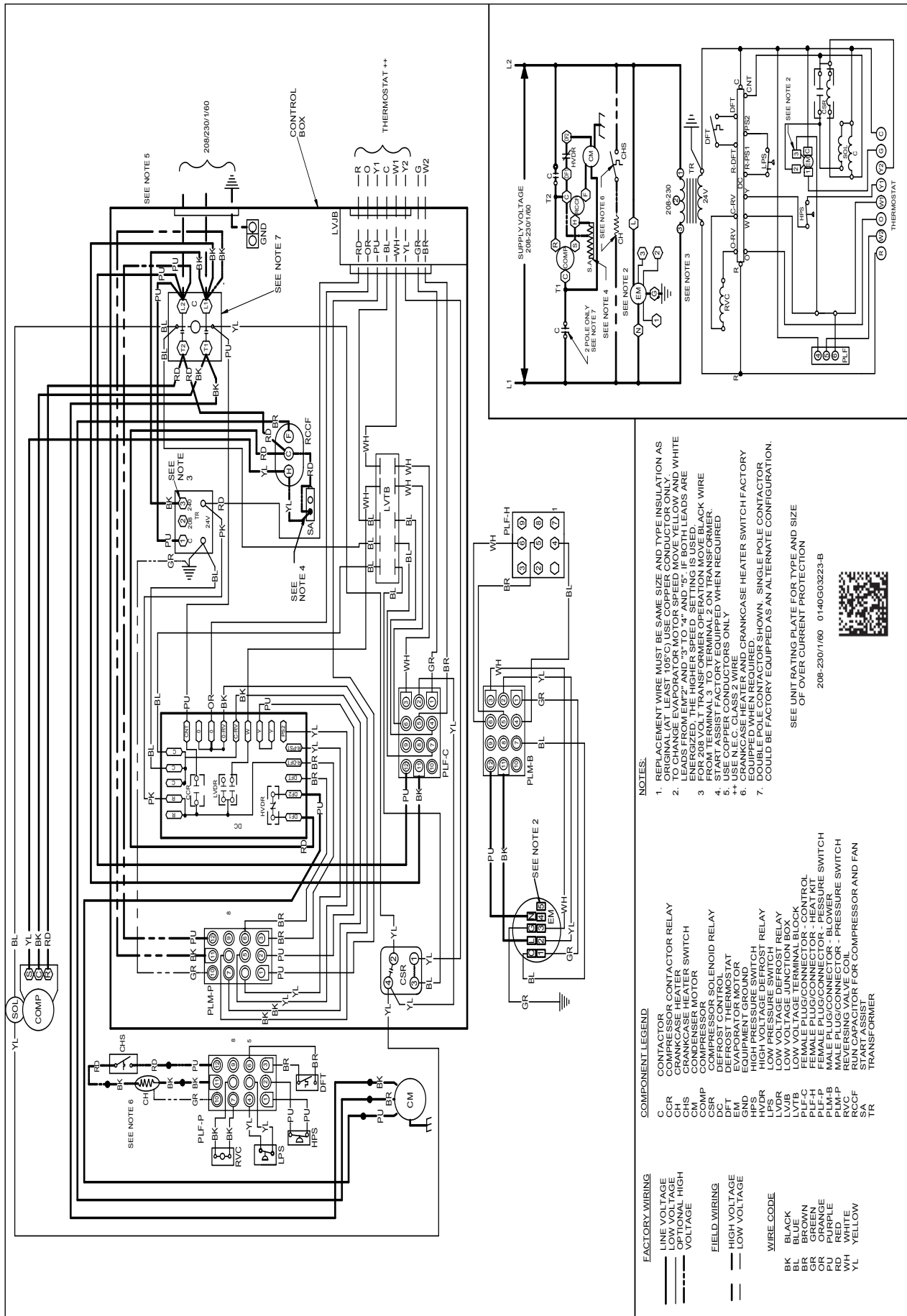

- NOTES:**
1. REPLACEMENT WIRE MUST BE SAME SIZE AND TYPE INSULATION AS ORIGINAL (AT LEAST 105°C). USE COPPER CONDUCTOR ONLY.
  2. TO CHANGE EVAPORATOR MOTOR SPEED MOVE YELLOW AND WHITE LEADS TO THE LOWER SPEED POSITION. THE LOWER SPEED IS ENERGIZED, THE HIGHER SPEED SETTING IS USED.
  3. FOR 208 VOLT TRANSFORMER OPERATION MOVE BLACK WIRE FROM THE 208V POSITION TO THE 230V POSITION.
  4. START ASSIST FACTORY EQUIPPED WHEN REQUIRED.
  5. USE N.E.C. CLASS 2 WIRE.
  6. CRANKCASE HEATER SWITCH FACTORY EQUIPPED WHEN REQUIRED.
  7. DOUBLE POLE CONTACTOR SHOWN. SINGLE POLE CONTACTOR COULD BE FACTORY EQUIPPED AS AN ALTERNATE CONFIGURATION.
- SEE UNIT RATING PLATE FOR TYPE AND SIZE OF OVER CURRENT PROTECTION  
208-230/160 01-40G03223-B

**COMPONENT LEGEND**

C	CONTACTOR
CCR	COMPRESSOR CONTACTOR RELAY
CH	CRANKCASE HEATER SWITCH
CM	FAN MOTOR
COMP	COMPRESSOR
CSR	COMPRESSOR SOLENOID RELAY
DFT	DEFROST THERMOSTAT
EM	EQUIPMENT GROUND
GND	GROUND
HVR	HIGH VOLTAGE DEFROST RELAY
LPS	LOW VOLTAGE DEFROST RELAY
LVJB	LOW VOLTAGE UNICON BOX
LVTB	LOW VOLTAGE TERMINAL BLOCK
PLF-C	FEMALE PLUG/CONNECTOR - CONTROL
PLF-H	FEMALE PLUG/CONNECTOR - PRESSURE SWITCH
PLM-B	MALE PLUG/CONNECTOR - BLOWER
PLM-P	MALE PLUG/CONNECTOR - PRESSURE SWITCH
RVC	RUN CAPACITOR FOR COMPRESSOR AND FAN
SA	START ASSIST
TR	TRANSFORMER

**FACTORY WIRING**

---	LINE VOLTAGE
---	LOW VOLTAGE
---	HIGH VOLTAGE
---	OPTIONAL HIGH VOLTAGE

**FIELD WIRING**

---	HIGH VOLTAGE
---	LOW VOLTAGE

**WIRE CODE**

BK	BLACK
BL	BLUE
BR	BROWN
GR	GREEN
OR	ORANGE
PU	PURPLE
RD	RED
TR	TRIPPLE
YL	YELLOW

**High Voltage:** Disconnect all power before servicing or installing this unit. Multiple power sources may be present. Failure to do so may cause property damage, personal injury, or death.

**WARNING**

Wiring is subject to change. Always refer to the wiring diagram or the unit for the most up-to-date wiring.



ACCESSORY DESCRIPTION	ITEM NUMBER	
	MEDIUM CHASSIS	LARGE CHASSIS
Concentric Kit	CDK36	CDK4872
Downflow Economizer	GPJMED102	GPJMED103
Downflow Internal Filter Rack	DDNIFRPCHEMM	DDNIFRPCHEML
Downflow Manual Damper	PGMDD101/102	PGMDD103
Downflow Motorized Damper	PGMDMD101/102	PGMDMD103
Downflow Square to Round	SQRPG101/102	SQRPG103
Economizer Wiring Harness (2-4 Tons)	0259G00215	0259G00215
Economizer Wiring Harness (5 Tons)	N/A	0259L00411
External Horizontal Filter Rack	DPHFRA	DPHFRA
Horizontal Duct Cover	20464501PDGK	20464502PDGK
Horizontal Economizer	DHZECNJPCHM	DHZECNJPCHL
Horizontal Manual Damper	PGMDH102	PGMDH103
Horizontal Motorized Damper	PGMDMH102	PGMDMH103
Horizontal Square to Round	SQRPGH101/102	SQRPGH103
Outdoor Thermostat & Emergency Heat Relay Kit	OT/EHR18-60	OT/EHR18-60
Outdoor Thermostat Kit w/ Lockout Stat	OT18-60A	OT18-60A
Roof Curb	D14CRBPGCHMA	D14CRBPGCHMA

**SINGLE-POINT KIT ACCESSORY KITS**

Select the single-point kit accessory based on the unit model.

MODEL	SINGLE-POINT KIT
APH1424M41**	SPK-30
APH1430M41**	SPK-35
APH1436M41**	SPK-40
APH1442M41**	SPK-40
APH1448M41**	SPK-50
APH1460M41**	SPK-60